

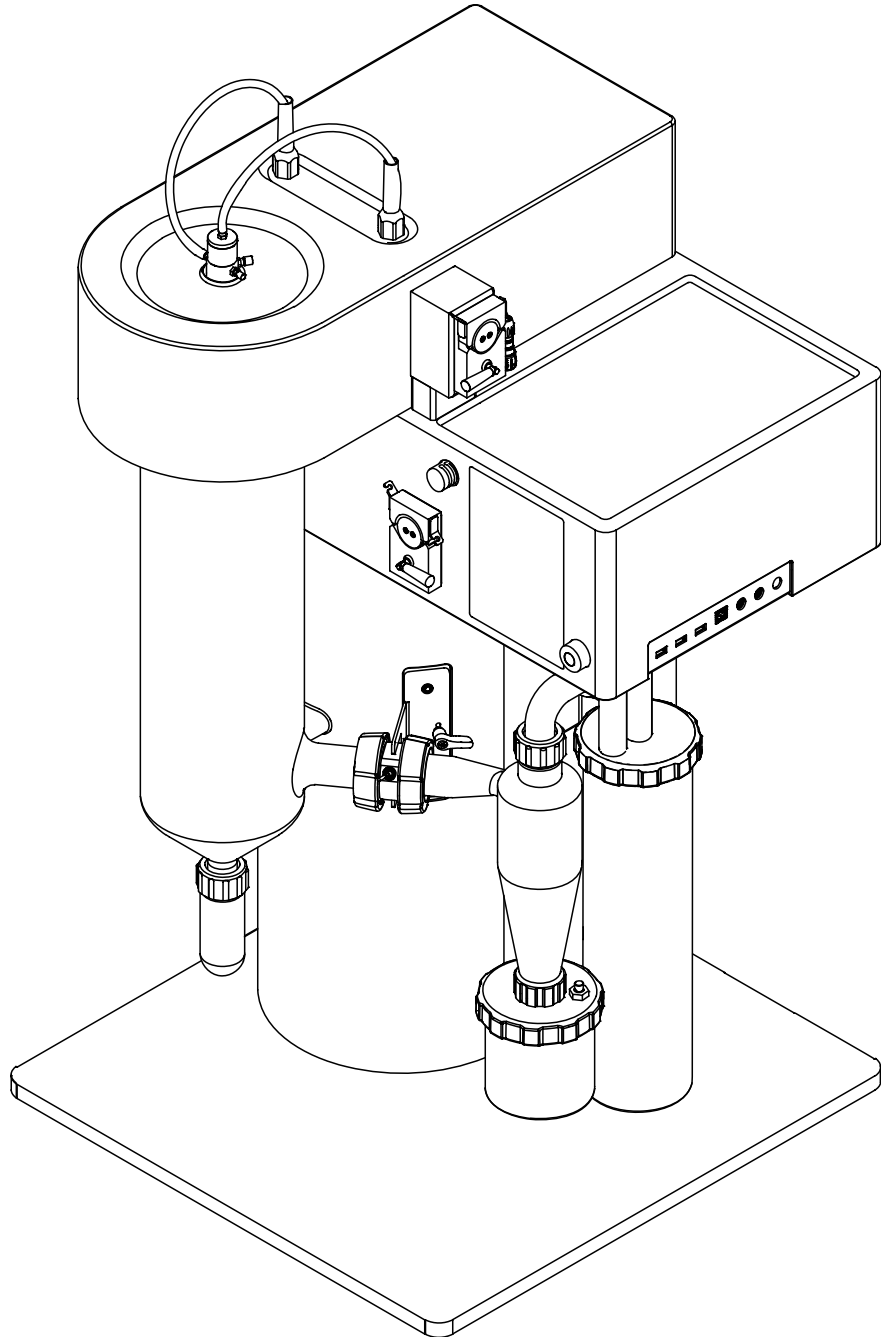

# MiniSprayDryer S-300

## Operation Manual



## **Imprint**

Product Identification:

Operation Manual (Original) MiniSprayDryer S-300  
11594255

Publication date: 06.2022

Version A

BÜCHI Labortechnik AG

Meierseggstrasse 40

Postfach

CH-9230 Flawil 1

E-Mail: [quality@buchi.com](mailto:quality@buchi.com)

BUCHI reserves the right to make changes to the manual as deemed necessary in the light of experience, especially with respect to structure, illustrations and technical details.

This manual is copyrighted. Information from it may neither be reproduced, distributed, or used for competitive purposes, nor made available to third parties. The manufacture of any component with the aid of this manual without prior written agreement is also prohibited.

## Table of contents

<b>1</b>	<b>About this document.....</b>	<b>8</b>
1.1	Mark-ups and symbols .....	8
1.2	Trademarks .....	8
1.3	Connected devices .....	8
<b>2</b>	<b>Safety .....</b>	<b>9</b>
2.1	Proper use .....	9
2.2	Use other than that intended .....	9
2.3	Staff qualification .....	9
2.4	Personal protective equipment .....	10
2.5	Warning notices in this document.....	10
2.6	Warning symbols .....	11
2.7	Residual risks .....	11
	2.7.1 Faults during operation.....	12
	2.7.2 Hot surfaces .....	12
	2.7.3 Dangerous vapors .....	12
	2.7.4 Dangerous particles.....	12
	2.7.5 Glass breakage .....	12
	2.7.6 Malfunction of a connected instrument (option).....	12
2.8	Modifications.....	13
<b>3</b>	<b>Product description.....</b>	<b>14</b>
3.1	Description of function .....	14
3.2	Configuration .....	15
	3.2.1 Front view .....	16
	3.2.2 Rear view.....	17
	3.2.3 Connections on the side .....	18
	3.2.4 Cylinder holder and sensor plugs .....	18
	3.2.5 Spray drying nozzle (Two fluid nozzle).....	19
3.3	Type plate .....	19
3.4	Scope of delivery .....	20
3.5	Technical data .....	20
	3.5.1 MiniSprayDryer S-300 .....	20
	3.5.2 Ambient conditions .....	21
	3.5.3 Materials .....	21
	3.5.4 Installation site.....	22
<b>4</b>	<b>Transport and storage .....</b>	<b>23</b>
4.1	Transport .....	23
4.2	Storage .....	23
4.3	Lifting the instrument .....	23

<b>5</b>	<b>Installation.....</b>	<b>25</b>
5.1	Before installation .....	25
5.2	Establishing electrical connections .....	25
5.3	Securing against earthquakes .....	25
5.4	Installing the spray gas supply .....	26
5.5	Installing peristaltic pump 2 (option) .....	26
5.6	Installations for remote services (option) .....	26
5.7	Installations for a spray drying mode .....	27
5.8	Installing the outlet filter holder .....	27
<b>6</b>	<b>Interface.....</b>	<b>29</b>
6.1	Layout of the interface .....	29
6.2	Navigation bar .....	29
6.2.1	Menu bar .....	30
6.2.2	Control panel .....	30
6.3	Function buttons .....	32
6.4	System settings .....	32
6.4.1	Changing the display settings.....	32
6.4.2	Changing the language settings .....	32
6.4.3	Changing the sound settings .....	32
6.4.4	Changing date and time .....	33
6.5	Customizing options .....	33
6.5.1	Changing the home screen background.....	33
6.5.2	Customize the control panel.....	33
6.5.3	Customize the report .....	34
6.5.4	Changing the measurement units.....	35

<b>7</b>	<b>Preparing for a spray drying process</b> .....	<b>36</b>
7.1	Preparing the outlet filter .....	36
7.1.1	Preparing the outlet filter with filter bag (Option) .....	36
7.1.2	Preparing the outlet filter with PTFE membrane (Option).....	37
7.2	Preparing the glass assembly .....	39
7.3	Preparing the product vessel.....	41
7.4	Preparing the spray drying nozzle .....	41
7.5	Preparing the peristaltic pump.....	43
7.5.1	Preparing the peristaltic pump for manual mode.....	43
7.5.2	Preparing the peristaltic pump for auto mode (option) .....	43
7.6	Preparing the sensors .....	44
7.6.1	Preparing the product temperature sensor (option).....	44
7.6.2	Preparing the outlet temperature sensor .....	45
7.7	Preparing the grounding (if no product sensor is used).....	46
7.8	Adjusting the peristaltic pump bed.....	46
7.9	Preparing the instrument for remote services (option) .....	47
7.10	Editing a method (Advanced and Corrosive only) .....	48
7.10.1	Creating a new method .....	48
7.10.2	Deleting a method .....	49
7.10.3	Changing the name of a method .....	49
7.10.4	Changing the description for a method.....	49
7.10.5	Changing the drying gas volume for a method.....	50
7.10.6	Changing the inlet temperature for a method .....	50
7.10.7	Changing the dispersion gas volume for a method .....	50
7.10.8	Changing the pump volume for a method .....	51
7.10.9	Changing the outlet temperature for a method.....	51
7.10.10	Changing the product temperature for a method.....	51
7.10.11	Changing the nozzle deblock frequency for method .....	52
7.10.12	Importing a method.....	52
7.10.13	Exporting a method .....	52
7.10.14	Loading a method.....	53
7.11	Editing a job list (Advanced and Corrosive only).....	53
7.11.1	Creating a new job list .....	53
7.11.2	Adding an entry to a job list .....	53
7.11.3	Deleting a job list .....	54
7.11.4	Deleting a job list entry .....	54
7.11.5	Loading a job list.....	54
7.12	Editing an auto mode sequence (Advanced and Corrosive only).....	55
7.13	Tagging table entries .....	55

<b>8</b>	<b>Carrying out a spray drying process</b> .....	<b>56</b>
8.1	Preparing the instrument for monitoring .....	56
8.2	Carrying out a spray drying process in open mode .....	56
8.2.1	Preparing the instrument for open mode .....	56
8.2.2	Starting a spray drying process in open mode .....	56
8.2.3	Tasks during spray drying (manual mode only).....	58
8.2.4	Ending a spray drying process in open mode .....	58
8.2.5	Shutting down the instrument .....	58
8.3	Carrying out a spray drying process in closed mode.....	59
8.3.1	Preparing the instrument for closed mode.....	59
8.3.2	Starting a spray drying process in closed mode.....	59
8.3.3	Tasks during spray drying (manual mode only).....	61
8.3.4	Ending a spray drying process in closed mode .....	61
8.3.5	Shutting down the instrument .....	61
8.4	Exporting run data .....	61
8.5	Deleting run data .....	62
8.6	Disconnecting the remote services.....	62
<b>9</b>	<b>Cleaning and servicing</b> .....	<b>63</b>
9.1	Regular maintenance work.....	63
9.2	Calibrating the peristaltic pumps .....	63
9.3	Cleaning the aspirator .....	64
9.4	Opening and closing the lower rear door.....	64
9.5	Opening and closing the upper rear door .....	65
9.6	Cleaning and servicing the drying gas hoses .....	65
9.7	Cleaning the filter.....	66
9.8	Cleaning the heater .....	66
9.9	Cleaning the glass component .....	66
9.10	Cleaning the nozzle .....	67
9.11	Cleaning and servicing the warning and directive symbols .....	68
9.12	Cleaning the housing.....	68
<b>10</b>	<b>Help with faults</b> .....	<b>69</b>
10.1	Troubleshooting.....	69
10.1.1	Troubleshooting general.....	69
10.1.2	Troubleshooting heater.....	71
10.1.3	Troubleshooting aspirator.....	72
10.2	Nozzle does not atomize .....	72
10.3	Changing the fuse .....	72
10.4	Sending instrument data to BUCHI customer service .....	73
10.5	No liquid delivery .....	73
<b>11</b>	<b>Taking out of service and disposal</b> .....	<b>74</b>
11.1	Taking out of service .....	74
11.2	Disposal.....	74
11.3	Returning the instrument .....	74

---

<b>12</b>	<b>Appendix .....</b>	<b>75</b>
12.1	Material information .....	75
12.1.1	Feeding tube.....	75
12.1.2	Drying gas hoses.....	75
12.2	Spare parts and accessories .....	76
12.2.1	Nozzle.....	76
12.2.2	Accessories .....	80
12.2.3	Glassware.....	82
12.2.4	Spare parts .....	86
12.2.5	Hoses .....	87
12.2.6	Documents .....	89

# 1 About this document

This operation manual is applicable for all variants of the instrument. Read this operation manual before operating the instrument and follow the instructions to ensure safe and trouble-free operation. Keep this operation manual for later use and pass it on to any subsequent user or owner.

BÜCHI Labortechnik AG accepts no liability for damage, faults and malfunctions resulting from not following this operation manual.

If you have any questions after reading this operation manual:

- ▶ Contact BÜCHI Labortechnik AG Customer Service.

<https://www.buchi.com/contact>

## 1.1 Mark-ups and symbols



### NOTE

This symbol draws attention to useful and important information.

- ☑ This character draws attention to a requirement that must be met before the instructions below are carried out.
- ▶ This character indicates an instruction that must be carried out by the user.
- ⇒ This character indicates the result of a correctly carried out instruction.

Mark-up	Explanation
<i>Window</i>	Software Windows are marked-up like this.
<i>Tab</i>	Tabs are marked-up like this.
<i>Dialog</i>	Dialogs are marked-up like this.
[ <i>Button</i> ]	Buttons are marked-up like this.
[ <i>Field names</i> ]	Field names are marked-up like this.
[ <i>Menu / Menu item</i> ]	Menus or menu items are marked-up like this.
<b>Status</b>	Status is marked-up like this.
<b>Signal</b>	Signals are marked-up like this.

## 1.2 Trademarks

Product names and registered or unregistered trademarks that are used in this document are used only for identification and remain the property of the owner in each case.

## 1.3 Connected devices

In addition to these operating instructions, follow the instructions and specifications in the documentation for the connected devices.



## 2 Safety

### 2.1 Proper use

The instrument is designed for spray drying.

The instrument can be used in laboratories for the following tasks:

- Spray drying

### 2.2 Use other than that intended

The use of the instrument other than described in proper use and specified in technical data is use other than that intended.

The operator is responsible for damages or hazards that are caused by use other than that intended.

Specially the following uses are not permitted:

- Use of the instrument with non-BUCHI products.
- Use of the instrument in closed mode with non-certified instruments.
- Use of the instrument in an environment with a potential risk of explosion or areas which require explosion-safe apparatus.
- Use of the instrument without an appropriate leading away exhaust gas from the working area.
- Use of the instrument with gases with unknown chemical composition.
- Use of the instrument with organic solvents (> 20 %) without Inert Loop.
- Use of the instrument with organic solvents (> 20 %) in open mode.
- Use of the instrument with samples containing peroxides.
- Use of the instrument with samples that can form peroxides.
- Use of the instrument with samples which produce oxygen during the processing.
- Use of the instrument with toxic substances without appropriate safety measures.
- Use of the instrument with biohazardous materials such as viruses or hazardous bacteria.
- Use of the instrument with samples which can block the feed channel of the nozzle.
- Use of the instrument with substances which might explode or ignite because of the processing.
- Use of the instrument with substances which might explode or ignite because of the selected parameters.
- Use of the instrument with corrosive samples in closed mode.
- Use of the instrument with corrosive samples other than the corrosive instrument version.
- Use of the instrument with any other Inert Loop than the S-395 without the O2 box. See Chapter 12.2.2 "Accessories", page 80

### 2.3 Staff qualification

Unqualified persons are unable to identify risks and are therefore exposed to greater dangers.

The instrument may only be operated by suitably qualified laboratory staff. These operating instructions are aimed at the following target groups:

### Users

Users are persons that meet the following criteria:

- They have been instructed in the use of the instrument.
- They are familiar with the contents of these operating instructions and the applicable safety regulations and apply them.
- They are able on the basis of their training or professional experience to assess the risks associated with the use of the instrument.

### Operator

The operator (generally the laboratory manager) is responsible for the following aspects:

- The instrument must be correctly installed, commissioned, operated and serviced.
- Only suitably qualified staff may be assigned the task of performing the operations described in these operating instructions.
- The staff must comply with the local applicable requirements and regulations for safe and hazard-conscious working practices.
- Safety-related incidents that occur while using the instrument should be reported to the manufacturer (quality@buchi.com).

### BUCHI service technicians

Service technicians authorized by BUCHI have attended special training courses and are authorized by BÜCHI Labortechnik AG to carry out special servicing and repair measures.

## 2.4 Personal protective equipment

Depending on the application, hazards due to heat and/or corrosive chemicals may arise.

- ▶ Always wear appropriate personal protective equipment such as safety goggles, protective clothing and gloves.
- ▶ Make sure that the personal protective equipment meets the requirements of the safety data sheets for all chemicals used.

## 2.5 Warning notices in this document





Warning notices warn you of dangers that can occur when handling the instrument. There are four danger levels, each identifiable by the signal word used.

Signal word	Meaning
DANGER	Indicates a danger with a high level of risk which could result in death or serious injury if not prevented.
WARNING	Indicates a danger with a medium level of risk which could result in death or serious injury if not prevented.
CAUTION	Indicates a danger with a low level of risk which could result in minor or medium-severity injury if not prevented.

Signal word	Meaning
NOTICE	Indicates a danger that could result in damage to property.

## 2.6 Warning symbols

The following warning symbols are displayed in this operation manual or on the instrument.

Symbol	Meaning
	General warning
	Device damage
	Dangerous electrical voltage
	Hot surface

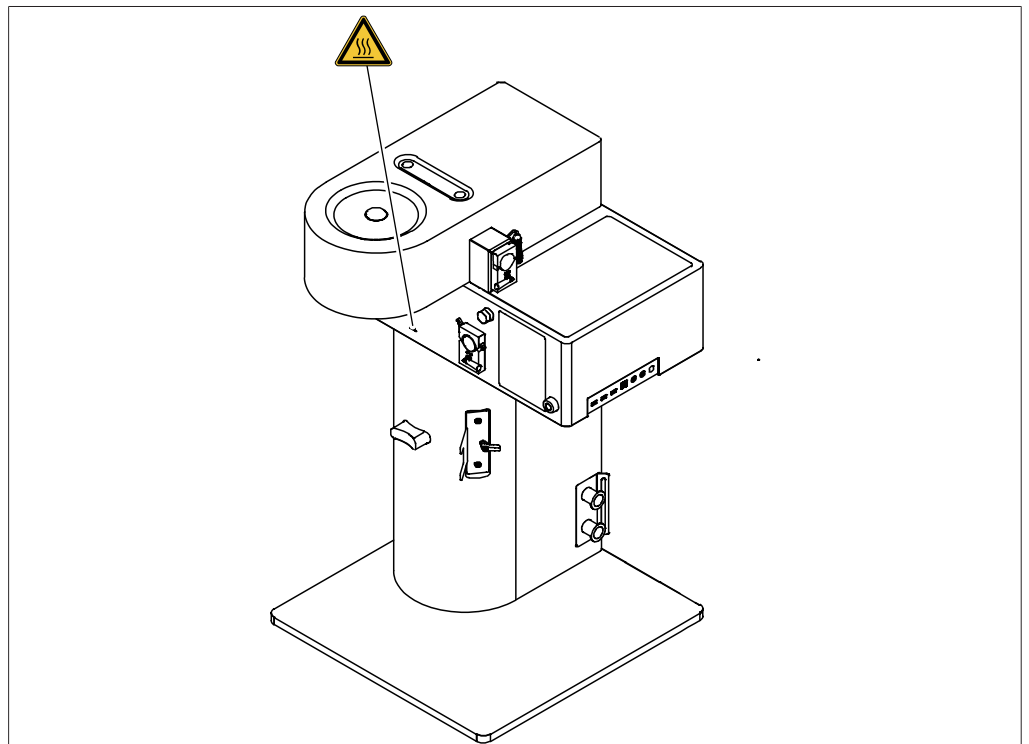

Fig. 1: Location of the warning symbols

## 2.7 Residual risks

The instrument has been developed and manufactured using the latest technological advances. Nevertheless, risks to persons, property or the environment can arise if the instrument is used incorrectly.

Appropriate warnings in this manual serve to alert the user to these residual dangers.

### 2.7.1 Faults during operation

If an instrument is damaged, sharp edges, moving parts or exposed electrical wires can cause injuries.

- ▶ Regularly check instruments for visible damage.
- ▶ If faults occur, switch off the instrument immediately, unplug the power cord and inform the operator.
- ▶ Do not continue to use instruments that are damaged.

### 2.7.2 Hot surfaces

The surfaces of the device can become very hot. If touched they can cause skin burns.

- ▶ Do not touch hot surfaces or else wear suitable protective gloves.

### 2.7.3 Dangerous vapors

The use of the instrument can produce dangerous vapors that are capable of causing life-threatening toxic effects.

- ▶ Do not inhale any vapors produced during processing.
- ▶ Ensure that vapors are removed by a suitable fume hood.
- ▶ Only use the device in well ventilated areas.
- ▶ If vapors escape from connections, check the seals concerned and replace them if necessary.
- ▶ Do not process any unknown fluids.
- ▶ Observe the safety data sheets for all substances used.

### 2.7.4 Dangerous particles

The use of the instrument can produce dangerous particles that can cause life-threatening toxic effects.

- ▶ Do not inhale any particles produced during processing.
- ▶ Ensure that particles are removed by a suitable fume hood.
- ▶ Only use the instrument in well ventilated areas.
- ▶ If particles escape from connections, check the seals concerned and replace them if necessary.
- ▶ Do not process any unknown fluids.
- ▶ Observe the safety data sheets for all substances used.

### 2.7.5 Glass breakage

Broken glass can cause severe cuts.

Damaged glass components may implode if subjected to a vacuum.

Minor damage to the ground joints impairs the sealing effect and may therefore diminish performance.

- ▶ Handle the flask and other glass components carefully and do not drop them.
- ▶ Always visually inspect glass components for damage every time they are to be used.
- ▶ Do not continue to use glass components that are damaged.
- ▶ Always wear protective gloves when disposing of broken glass.

### 2.7.6 Malfunction of a connected instrument (option)

A malfunction on a connected instrument can cause poisoning or death.

- ▶ Make sure that the connected instrument is prepared and maintained according to the user documentation.

## 2.8 Modifications

Unauthorized modifications can effect safety and lead to accidents.

- ▶ Use only genuine BUCHI accessories, spare parts and consumables.
- ▶ Carry out technical changes only with prior written approval from BUCHI.
- ▶ Only allow changes to be made by BUCHI service technicians.

BUCHI accepts no liability for damage, faults and malfunctions resulting from unauthorized modifications.

### 3 Product description

#### 3.1 Description of function

Spray drying is a processing technology to transform a liquid feedstock into a dried powder through four fundamental steps:

- Atomization of the feed into a spray
- Spray gas contact
- Solvent evaporation
- Separation of the dried product from the drying medium

The following spray drying modes are available:

<b>Spray drying mode</b>	<b>Solvent composition</b>
Open mode	up to 20 % organic solvent
Closed mode with Inert Loop (When using Ultrasonic Package accessory inert gas adapter is necessary)	between 90 % - 100 % organic solvent
Closed mode with Inert Loop and Dehumidifier (When using Ultrasonic Package accessory inert gas adapter is necessary)	between 20 % - 80 % organic solvent

## **3.2 Configuration**

### 3.2.1 Front view

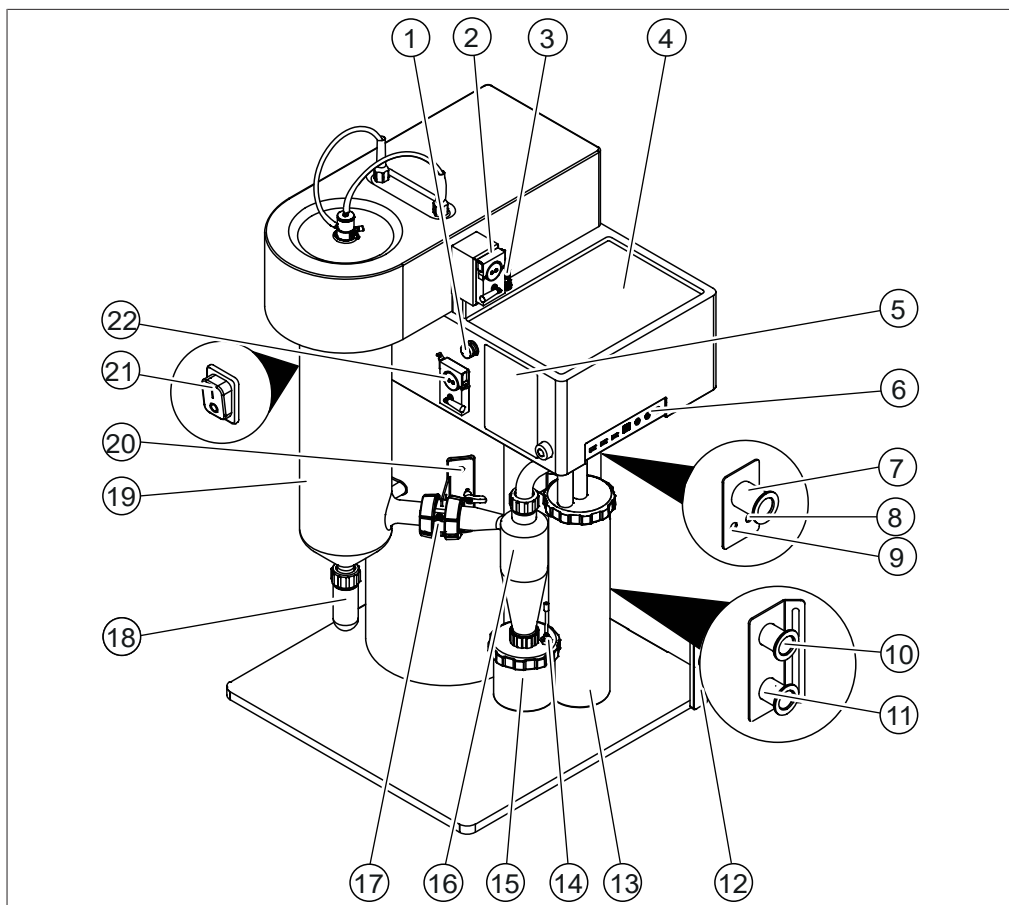

Fig. 2: Front view

- |    |  |    |   |
|----|--|----|---|
| 1  | Switch valve<br>(Advanced and Corrosive only)          | 2  | Peristaltic pump 2 (option)   |
| 3  | Plug peristaltic pump 2                                | 4  | Sample and solvent place area   |
| 5  | Interface<br>See Chapter 6 "Interface", page 29        | 6  | Connections on the side<br>See Chapter 3.2.3 "Connections on the side", page 18                   |
| 7  | Inlet from filter / cyclone<br>(marked <b>Filter</b> ) | 8  | Filter pressure inlet<br>(marked <b>IN</b> )  |
| 9  | Filter pressure outlet<br>(marked <b>OUT</b> )         | 10 | Aspirator outlet  |
| 11 | Heater Inlet   | 12 | Tubing protection (option)  |
| 13 | Outlet Filter  | 14 | Product temperature sensor (option)   |
| 15 | Product collection vessel                              | 16 | Cyclone   |
| 17 | Connection piece with outlet temperature sensor        | 18 | Separation flask  |
| 19 | Spray cylinder   | 20 | Cylinder holder and sensor plugs<br>See Chapter 3.2.4 "Cylinder holder and sensor plugs", page 18 |
| 21 | On/Off master switch                                   | 22 | Peristaltic pump 1  |



### 3.2.2 Rear view

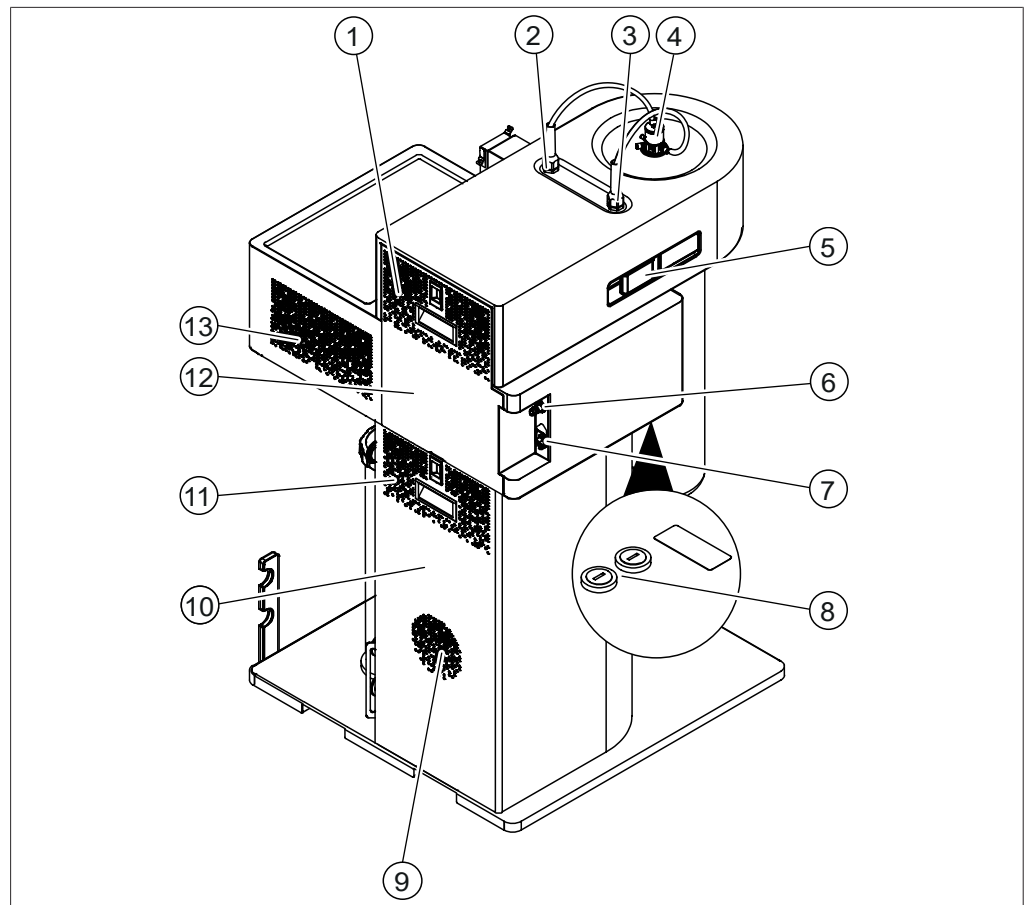

Fig. 3: Rear view

- |    |                         |    |   |
|----|-------------------------|----|---|
| 1  | Ventilation slots       | 2  | Compressed air for the nozzle cleaner   |
| 3  | Spray gas               | 4  | Nozzle<br>See Chapter 3.2.5 "Spray drying nozzle (Two fluid nozzle)", page 19 |
| 5  | Handle                  | 6  | Spray gas connection  |
| 7  | Power supply connection | 8  | Fuses   |
| 9  | Aspirator ventilation   | 10 | Lower rear door   |
| 11 | Ventilation slots       | 12 | Upper rear door   |
| 13 | Ventilation slots       |    |   |

### 3.2.3 Connections on the side

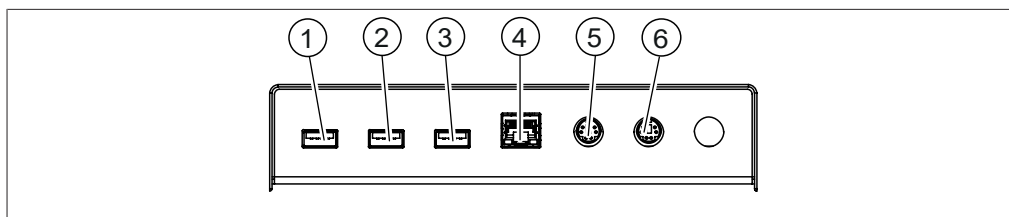

Fig. 4: Connections

- |   |      |   |      |
|---|------|---|------|
| 1 | USB  | 2 | USB  |
| 3 | USB  | 4 | LAN  |
| 5 | RJ32 | 6 | RJ32 |

### 3.2.4 Cylinder holder and sensor plugs

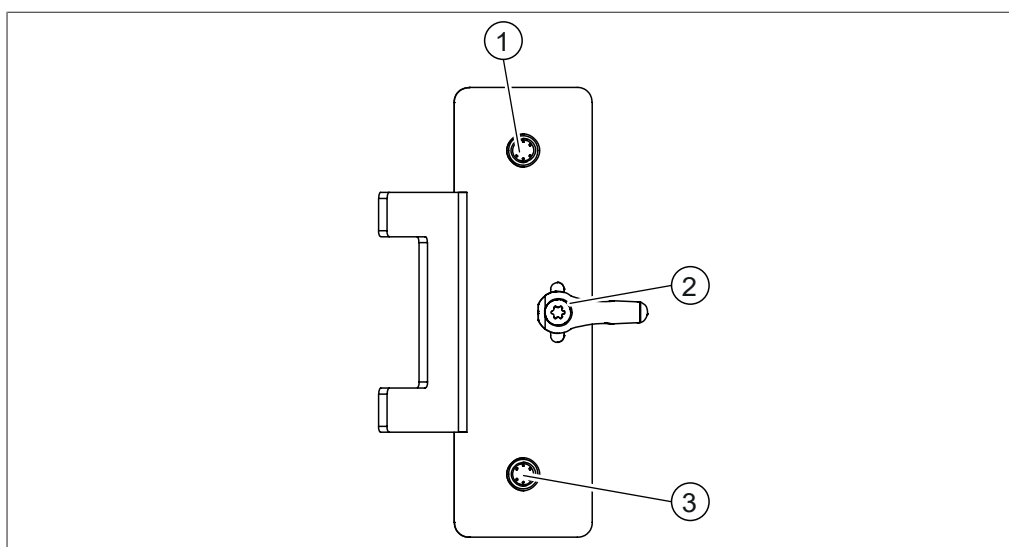

Fig. 5: Adjustment and sensor plugs

- |   |                                 |   |        |
|---|---------------------------------|---|--------|
| 1 | Outlet temperature sensor port  | 2 | Handle |
| 3 | Product temperature sensor port |   |        |

### 3.2.5 Spray drying nozzle (Two fluid nozzle)

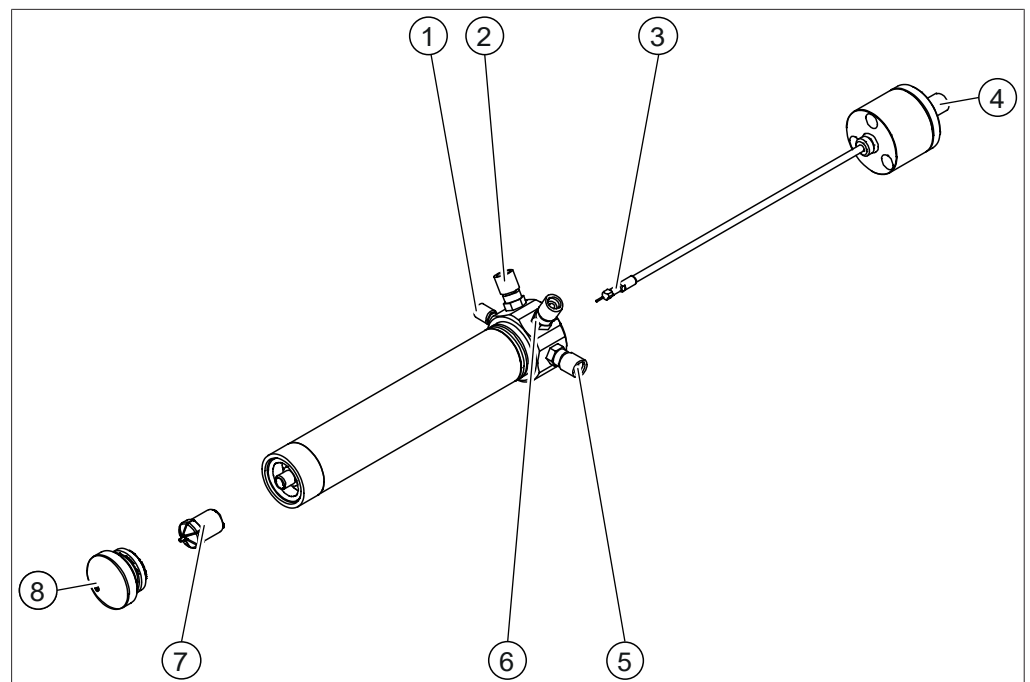

Fig. 6: Spray drying nozzle

- |   |  |
|---|--|
| 1 Feeding tube connection<br>(marked <b>FEED</b> )  | 2 Cooling in connection<br>(marked <b>C IN</b> )   |
| 3 Nozzle needle                                     | 4 Cleaning nozzle gas connection                   |
| 5 Dispersion gas connection<br>(marked <b>GAS</b> ) | 6 Cooling out connection<br>(marked <b>C OUT</b> ) |
| 7 Nozzle tip  | 8 Nozzle cap                                       |

### 3.3 Type plate

The type plate identifies the instrument. The type plate is located at the rear of the instrument.

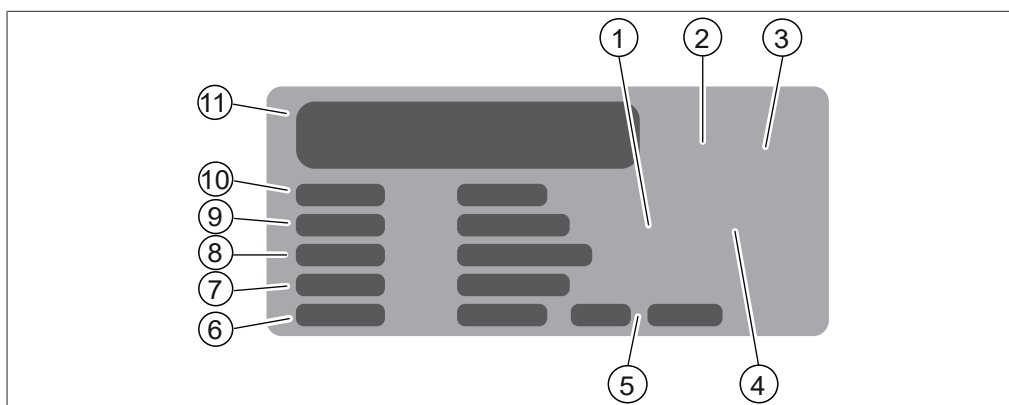

Fig. 7: Type plate

- |    |                                    |    |   |
|----|------------------------------------|----|---|
| 1  | Symbol for "electronics recycling" | 2  | Initial product code                              |
| 3  | Approvals                          | 4  | Symbol for "Do not dispose of as household waste" |
| 5  | Year of manufacture                | 6  | Power consumption maximum                         |
| 7  | Frequency                          | 8  | Input voltage range                               |
| 9  | Serial number                      | 10 | Instrument name                                   |
| 11 | Company name and address           |    |   |

### 3.4 Scope of delivery



#### NOTE

The scope of delivery depends of the configuration of the purchase order.

Accessories are delivered as per the purchase order, order confirmation, and delivery note.

### 3.5 Technical data

#### 3.5.1 MiniSprayDryer S-300

	MiniSprayDryer S-300	MiniSprayDryer S-300 Advanced	MiniSprayDryer S-300 Corrosive
Dimensions (W x D x H)	620 mm x 640 mm x 1052 mm	620 mm x 640 mm x 1052 mm	620 mm x 640 mm x 1052 mm
Weight (without glass assembly)	54 kg	54 kg	54 kg
Weight (with glass assembly)	62.5 kg	62.5 kg	62.5 kg
Connection voltage	220 - 240 ± 10 % VAC	220 - 240 ± 10 % VAC	220 - 240 ± 10 % VAC
Power consumption	max. 2300 W	max. 2300 W	max. 2300 W
Fuse	10 AT	10 AT	10 AT
Overvoltage category	II	II	II
Frequency	50 / 60 Hz	50 / 60 Hz	50 / 60 Hz

	<b>MiniSprayDryer S-300</b>	<b>MiniSprayDryer S-300 Advanced</b>	<b>MiniSprayDryer S-300 Corrosive</b>
IP Code	IP20	IP20	IP20
Pollution degree	2	2	2
Minimum clearance on all sides	100 mm	100 mm	100 mm
Spray drying gas	Nitrogen Compressed air	Nitrogen Compressed air	Nitrogen Compressed air
Max. temperature	220 / 250 °C	220 / 250 °C	220 / 250 °C
Max. flow rate	35 m <sup>3</sup> /h	35 m <sup>3</sup> /h	35 m <sup>3</sup> /h
Spray gas range	80-1800 l/min	80-1800 l/min	80-1800 l/min
Max. pressure spray gas	7 bar	7 bar	7 bar
Sample feed	0.1-30 ml/min	0.1-30 ml/min	0.1-30 ml/min
External connection drying gas	KF25	KF25	KF25
Certificate	CSA / CE	CSA / CE	CSA / CE

### 3.5.2 Ambient conditions

For indoor use only.

Max. altitude above sea level	2000 m
Ambient and storage temperature	5 – 40 °C
Maximum relative humidity	80% for temperatures up to 31 °C decreasing linearly to 50 % relative humidity at 40 °C

### 3.5.3 Materials

<b>Component</b>	<b>Materials of construction</b>
Housing	PUR (Polyurethane) foam painted
Glass assembly	3.3 borosilicate glass
Nozzle	Stainless steel
Heater	Stainless steel
Product feed tube	Silicone and tygon
Cover of the product collection vessel	PA12
Seal of the product collection vessel	FPM
Seal cyclone	
Drying gas tube	TPR (Thermoplastic elastomers)/PTFE (Polytetrafluoroethylene)
Acid resistant coated metal	
Acid resistant metal	

### 3.5.4 Installation site

- The installation site meets the safety requirements. See Chapter 2 "Safety", page 9
- The installation site has a firm, level and nonslip surface.
- The installation site has no obstacles (e.g. water taps, drains, etc.).
- The installation site has an own mains outlet socket for the instrument.
- The installation site is not exposed to external thermal loads, such as direct solar radiation.
- The installation site has enough space that cables / tubes can be routed safely.
- The installation site meets the requirements for the connected devices. See related documentation
- The installation site meets the specifications according to the technical data (e.g. weight, dimension, etc.). See Chapter 3.5 "Technical data", page 20
- The installation site fits basic electromagnetic environment / Emission Class B.

## 4 Transport and storage

### 4.1 Transport



#### NOTICE

##### Risk of breakage due to incorrect transportation

Make sure that the instrument is fully dismantled.

Pack every instrument components properly to prevent breakage. Use the original packaging whenever possible.

Avoid sharp movements during transit.

- ▶ After transporting, check the instrument and all glass components for damage.
- ▶ Damage that has occurred in transit should be reported to the carrier.
- ▶ Keep packaging for future transportation.

### 4.2 Storage

- ▶ Make sure that the ambient conditions are complied with (see Chapter 3.5 "Technical data", page 20).
- ▶ Wherever possible, store the device in its original packaging.
- ▶ After storage, check the device, all glass components, seals and tubing for damage and replace if necessary.

### 4.3 Lifting the instrument



#### WARNING

##### Danger due to incorrect transportation

The possible consequences are crushing injuries, cuts and breakages.

- ▶ Lift the instrument with three persons at the same time.
- ▶ Lift the instrument at the points indicated.



#### NOTICE

##### Dragging the instrument can damage the feet of the instrument.

- ▶ Lift the instrument when positioning or re-locating.

► Lift the instrument at the points indicated.

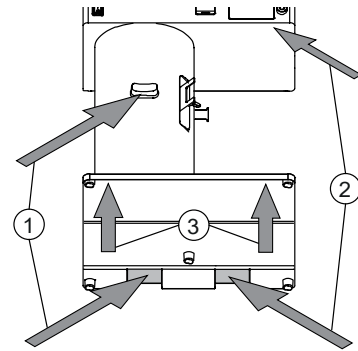



## 5 Installation

### 5.1 Before installation



#### NOTICE

##### Instrument damage due to switching it on too early.

Switching on the instrument too early after transportation can cause damage.

- ▶ Climatize the instrument after transportation.

### 5.2 Establishing electrical connections



#### NOTICE

##### Risk of instrument damage because of not suitable power supply cables.

Not suitable power supply cables can cause bad performance or an instrument damage

- ▶ Use only BUCHI power supply cables.

Precondition:

- The electrical installation is as specified on the type plate.
  - The electrical installation is equipped with a proper grounding system.
  - The electrical installation is equipped with suitable fuses and electrical safety features.
  - The installation site is as specified in the technical data. See Chapter 3.5 "Technical data", page 20
- ▶ Connect the power supply cable to the connection on the instrument. See Chapter 3.2 "Configuration", page 15

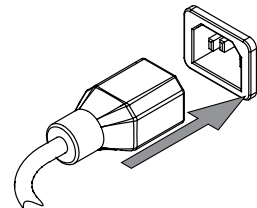

- ▶ Connect the mains plug to an own mains outlet socket.

### 5.3 Securing against earthquakes

The instrument has an earthquake fixing point to protect the device against falling.

- ▶ Tie the lashing mount to a fixed point using strong cord or a wire.

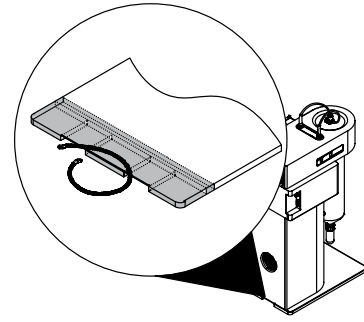

## 5.4 Installing the spray gas supply

Precondition:

- The spray gas supply meets the specifications.  
See Chapter 3.5 "Technical data", page 20
- ▶ Attach the air supply to the instrument.

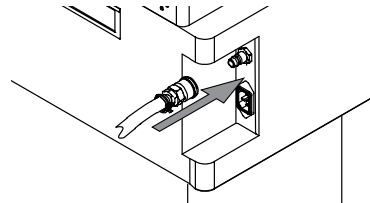

## 5.5 Installing peristaltic pump 2 (option)

- ▶ Attach the peristaltic pump 2 to the instrument.

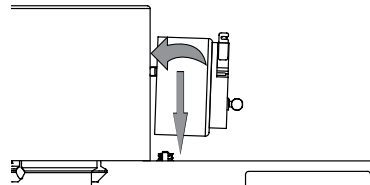

- ▶ Connect the cable to the instrument.

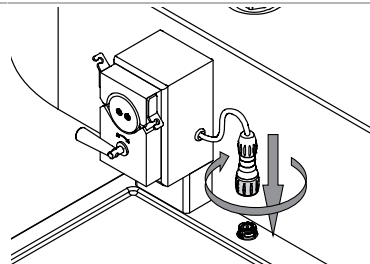

## 5.6 Installations for remote services (option)

Navigation path:



Precondition:

- Instrument and mobile device are in the same network.
- The app is installed on the mobile device.
- ▶ Connect the network cable to the socket marked **LAN**. See Chapter 3.2 "Configuration", page 15

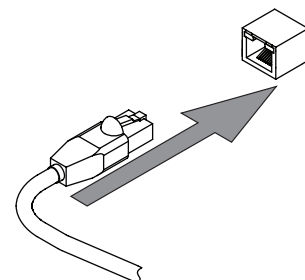

- ▶ Navigate to the *Remote and Monitoring* menu according the navigation path.
- ▶ Start the app on the mobile device.

- ▶ Tap the *[Scan QR Code]* button on the app.
- ▶ Scan the QR code with the app.
- ⇒ The mobile device and the instrument are connected.

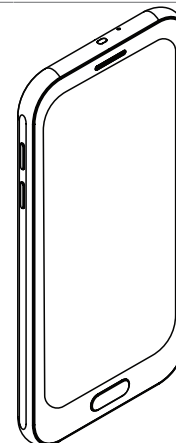

## 5.7 Installations for a spray drying mode

For installations for a spray drying mode, see separate installation manuals.

- *"MiniSprayDryer S-300 in closed mode with Dehumidifier and Inert Loop"*
- *"MiniSprayDryer S-300 in closed mode with Inert Loop"*
- *"MiniSprayDryer S-300 in open pressure mode"*
- *"MiniSprayDryer S-300 in open suction mode"*

## 5.8 Installing the outlet filter holder



### ⚠ WARNING

#### Not installed filter holder

A not installed filter holder will result in an inadequately grounded instrument.

A not sufficient grounded instrument can cause fires.

- ▶ Install the filter holder.
- ▶ Put the filter holder onto the instrument.

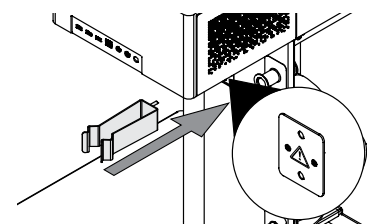

- ▶ Attach the filter holder to the instrument with the knurl nuts.

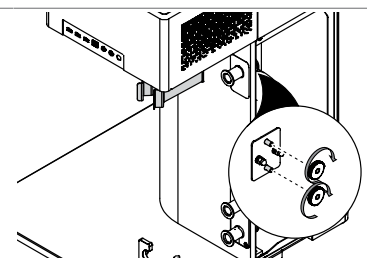

- ▶ Make sure that the warning sign is not visible anymore.

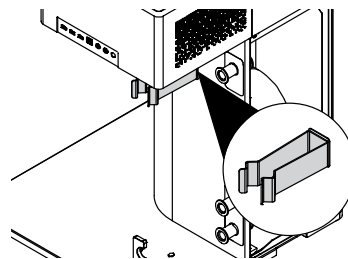

## 6 Interface

### 6.1 Layout of the interface

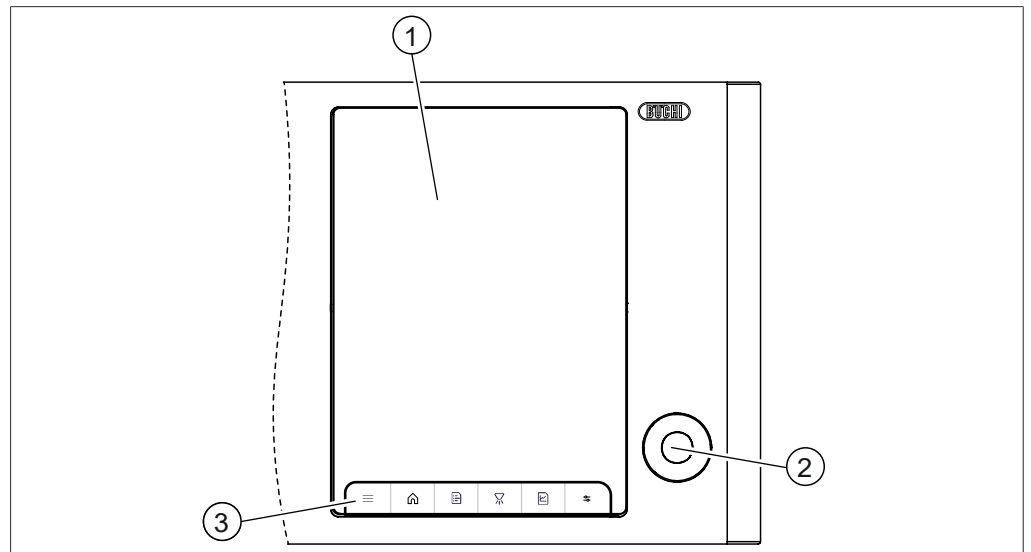
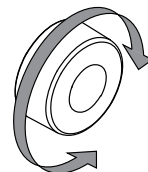

Fig. 8: Interface

- 1 Content area
- 2 Navigation control
- 3 Navigation bar  
See Chapter 6.2 "Navigation bar", page 29

#### Using the navigation control



- ▶ Select an entry.



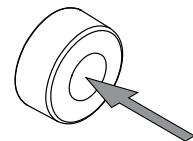



- ▶ Confirm the selected entry.









### 6.2 Navigation bar

Icon	Description	Further information
	Menu bar	Shows available menus. See Chapter 6.2.1 "Menu bar", page 30
	Home panel	Shows the home screen. See Chapter 10.4 "Sending instrument data to BUCHI customer service", page 73



Icon	Description	Further information
	<i>Methods</i> panel	<ul style="list-style-type: none"> <li>• Creating methods</li> <li>• Editing methods</li> <li>• Method library</li> </ul> <p>See Chapter 7.10 "Editing a method (Advanced and Corrosive only)", page 48</p>
	<i>Job Lists</i> panel	<p>Task organization tool.</p> <p>See Chapter 7.11 "Editing a job list (Advanced and Corrosive only)", page 53</p>
	<i>Control</i> panel	<p>Controlling and editing parameters during a run.</p> <p>See Chapter 6.2.2 "Control panel", page 30</p>
	<i>Runs</i> panel	<p>Shows the details of carried out runs.</p> <p>See Chapter 8.4 "Exporting run data", page 61</p>

### 6.2.1 Menu bar





Icon	Description	Further Information
	<i>Remote and Monitoring</i>	See Chapter 5.6 "Installations for remote services (option)", page 26
	<i>Settings</i>	<p>See Chapter 6.4 "System settings", page 32</p> <p>See Chapter 6.5 "Customizing options", page 33</p>
	<i>Notification</i>	Displayed when a notification appears.
	<i>Instrument</i>	<p>Shows details about the spray drying system.</p> <p>Calibrations</p> <p>See Chapter 9.2 "Calibrating the peristaltic pumps", page 63</p> <p>Shows counters and additional information.</p>
	<i>Logs</i>	Shows the notification history.
	<i>Update</i>	Displayed when an update is available.
	<i>About</i>	Shows legal information.

### 6.2.2 Control panel

The control panel consists on three sections:





Icon	Name	Description
	Control screen	See Chapter "Control screen", page 31
	Live graphs screen	Shows live charts of the parameters.
	Focus parameters screen	Visualizes selected parameters in a larger size. See Chapter "Customizing the focus parameters screen", page 34

### Control screen

Icon	Explanation
	Solvent
	Sample
	Stopping the drying gas without stopping the recording of the run.
	Auto mode

Function	Description
<i>[Drying gas]</i>	Set the aspirator flow m <sup>3</sup> /h. Start the aspirator.
<i>[Inlet T]</i>	Set of the inlet temperature. Start heating up the instrument.
<i>[Disper. gas]</i>	Set the spray gas volume in L/h. Start the gas flow.
<i>[Pump 1]</i>	Peristaltic pump rate in volume per hour. Select between detection and flow volume. Start the spray process.
<i>[Pump 2] (option)</i>	Peristaltic pump rate in volume per hour. Select between detection and flow volume. Start the spray process.
<i>[Outlet T]</i>	Shows the temperature of the drying gas measured at the end of the drying chamber.
<i>[Product T]</i>	Shows the temperature of the drying gas measured in the product collection vessel.
<i>[Deblock]</i>	Setting for the frequency and quantity of the nozzle needle.
<i>[Filter press.]</i>	Shows the filter permeability in percent or mbar. See Chapter "Customizing the control screen", page 33

## 6.3 Function buttons

Icon	Explanation
	[Load] button
	[Options] button
	[Copy] button
	[Delete] button

## 6.4 System settings

### 6.4.1 Changing the display settings

The following settings can be changed:

Display setting	Explanation
[Dark Mode]	Uses light texts and icons on a dark background.
[Brightness]	Changing the display brightness.
[Dimmer]	Setting the time the display starts to reduce the brightness.

#### Navigation path

→  → [System]

- ▶ Navigate to the *System* submenu according to the navigation path.
- ▶ Select the *Display* section.
- ▶ Carry out the changes according to your needs.

### 6.4.2 Changing the language settings

#### Navigation path

→  → [Customize]

- ▶ Navigate to the *Customize* submenu according to the navigation path.
- ▶ Select the *Localization* section.
- ▶ Select required language from the drop-down menu.

### 6.4.3 Changing the sound settings

The following sound settings are changeable:

Sound option	Explanation
[System Volume]	Volume setting
[Keyboard Clicks]	Setting the keyboard clicks to ON/OFF

#### Navigation path

→  → [System]



- ▶ Navigate to the *System* submenu according to the navigation path.
- ▶ Select the *Sound* section.
- ▶ Carry out the changes according to your needs.

#### 6.4.4 Changing date and time

Options	Explanations
[Automatic Date and Time]	Set the correct time on the instrument automatically
[Set Date]	Visible when the [Automatic Date and Time] action is off.
[Select Time Zone]	Specify a time offset from local time.

##### Navigation path

→  → [System]

- ▶ Navigate to the *System* submenu according to the navigation path.
- ▶ Select the *Date and Time* section.
- ▶ Carry out the changes according to your needs.

### 6.5 Customizing options

#### 6.5.1 Changing the home screen background

The following graphic formats are possible:

- .png
- .jpg

##### Navigation path

→  → [System]

Precondition:

- A data storage device with graphics is connected to the instrument.
- ▶ Navigate to the *System* submenu according to the navigation path.
- ▶ Select the *Home Screen* section.
- ▶ Tap the [ + ] button.
  - ⇒ The display shows the selectable graphics.
- ▶ Select the graphic you wish to enter.

#### 6.5.2 Customize the control panel

##### Customizing the control screen

The following display options are available:

Display option	Explanation
Filter Blockage	Shows the blockage level of the outlet filter in %.
Filter Pressure	The pressure measured at the outlet of the filter in mbar

### Navigation path

---

→  → [Customize]

---

- ▶ Navigate to the *Customize* submenu according to the navigation path.
- ▶ Select the *Control Panel* section.
- ▶ Select the filter option you wish to use from the drop-down menu for the [Show Pressure] action.

### Customizing the focus parameters screen

The following options can be selected for each of the three positions:

- [Product Temperature]
- [Spray Gas]
- [Drying Gas]
- [Filter Blockage]
- [Filter Pressure]
- [Outlet Temperature]
- [Inlet Temperature]

### Navigation path

---

→  → [Customize]

---

- ▶ Navigate to the *Customize* submenu according to the navigation path.
- ▶ Select the *Control Panel* section.
- ▶ Select the option you wish to show from the drop-down menu for each position action.

## 6.5.3 Customize the report

The following report entries are customizable:

- Logo (.jpg or .png only)
- Address

### Navigation path

---

→  → [Customize]

---

Precondition:

- If necessary, a data storage device with a graphic for the logo is connected to the instrument.
- ▶ Navigate to the *Customize* submenu according to the navigation path.
- ▶ Select the *Report* section.
- ▶ Tap the [ + ] button.
  - ⇒ The display shows the selectable graphics.
- ▶ Select the graphic you wish to enter.

- ▶ Select the action [*Company Address*] action.
  - ⇒ The display shows a dialog with an alphanumeric input box.
- ▶ Enter the address.
  - ⇒ The entered values are changed.

#### 6.5.4 Changing the measurement units

The following units are changeable:

Type	Available unit
Temperature	°C
	°F
Pressure	metric
	imperial

#### Navigation path

→  → [*Customize*]

- ▶ Navigate to the *Customize* submenu according to the navigation path.
- ▶ Select the *Localization* section.
- ▶ Select the measurement units you wish to use.

## 7 Preparing for a spray drying process

### 7.1 Preparing the outlet filter

#### 7.1.1 Preparing the outlet filter with filter bag (Option)

**NOTE**

Removing is done in reverse sequence.

- ▶ Put the filter bag on the filter body.

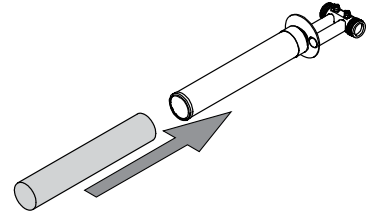

- ▶ Secure the filter bag in place with quick release fastener.

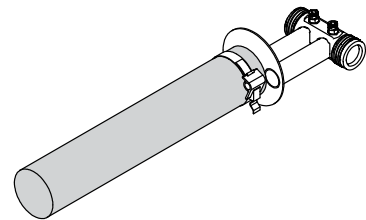

- ▶ Put the prepared filter body in the filter vessel.
- ▶ Secure the filter body in place with the cap nut.

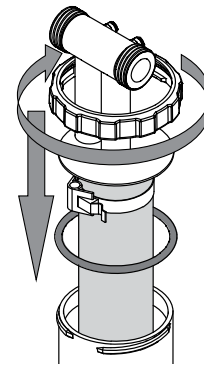

- ▶ Put the filter in the filter holder.

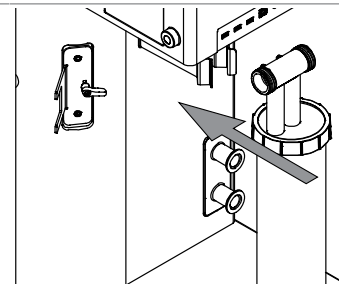

- ▶ Make sure that the filter is attached to the filter holder.

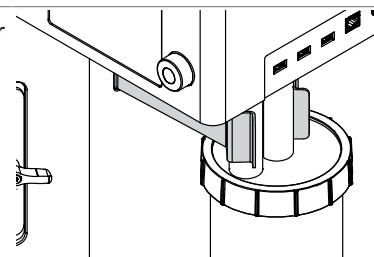

- ▶ Connect the filter with the instrument.

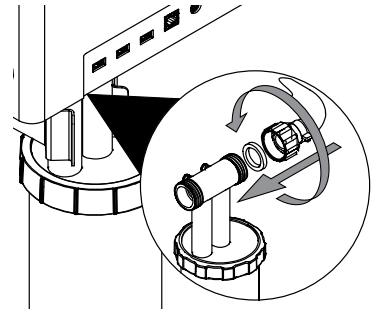

- ▶ Attach the filter outlet sensor tube to the filter.

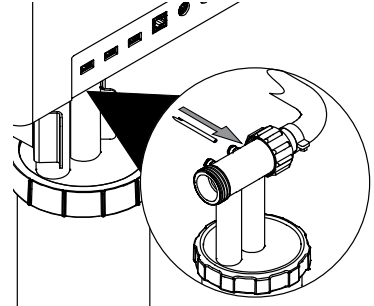

- ▶ Attach the filter inlet sensor tube to the filter.

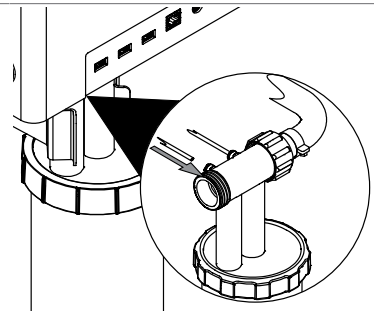

### 7.1.2 Preparing the outlet filter with PTFE membrane (Option)



#### NOTE

Removing is done in reverse sequence.

- ▶ Pull the PTFE membrane on the filter body.

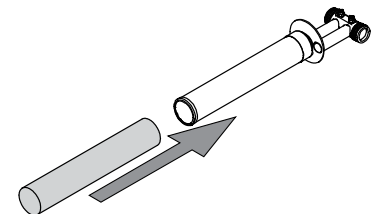

- ▶ Secure the filter bag in place with quick release fastener.

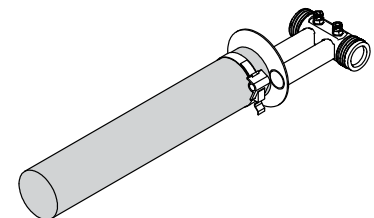

- ▶ Turn in the filter membrane.

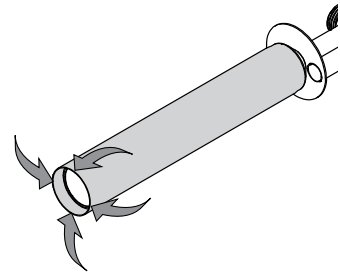

- ▶ Put the plug on the bottom.

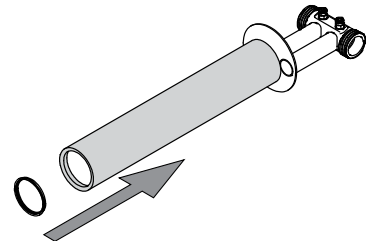

- ▶ Put the prepared filter body in the filter vessel.
- ▶ Secure the filter body in place with the cap nut.

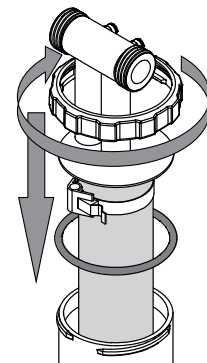

- ▶ Put the filter in the filter holder.

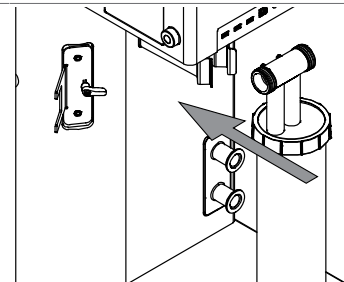

- ▶ Make sure that the filter is attached to the filter holder.

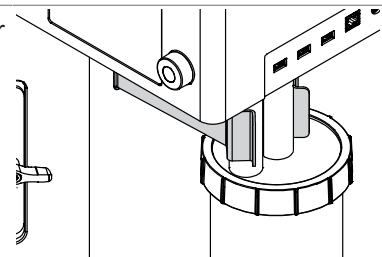

- ▶ Connect the filter with the instrument.

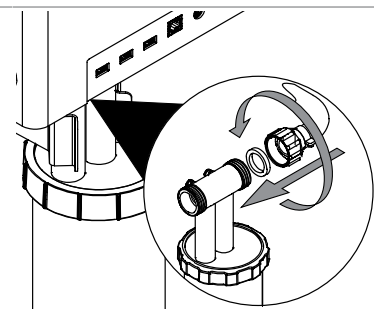

- ▶ Attach the filter outlet sensor tube to the filter.

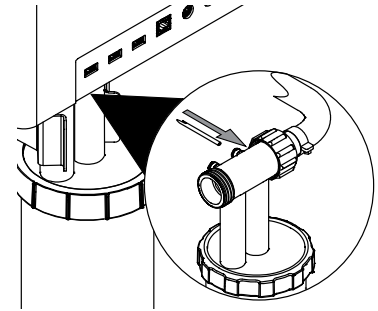

- ▶ Attach the filter inlet sensor tube to the filter.

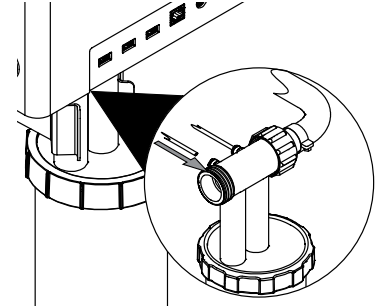

## 7.2 Preparing the glass assembly



### NOTE

Removing is done in reverse sequence.

Precondition:

- The filter is prepared. See Chapter 7.1 "Preparing the outlet filter", page 36

- ▶ Open the handle at the adjustment.

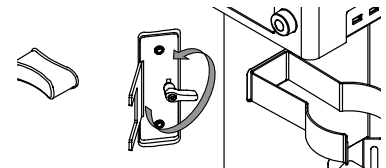

- ▶ Attach the seal holder with the seal onto the instrument.

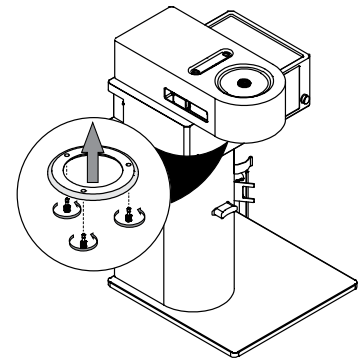

- ▶ Attach the separation flask to the spray cylinder.

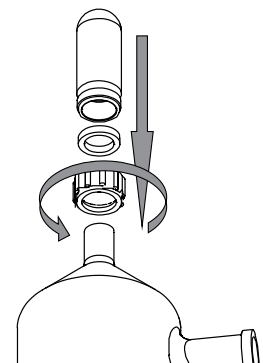

- ▶ Attach the coupling flange to the spray cylinder.

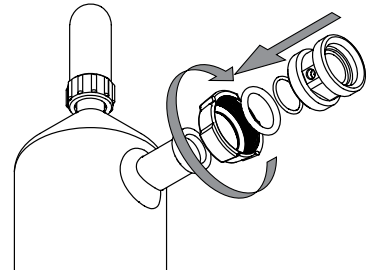

- ▶ Open the handle.

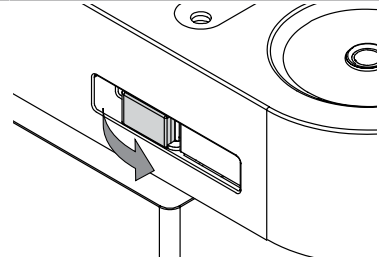

- ▶ Press the prepared spray cylinder on the seal holder.

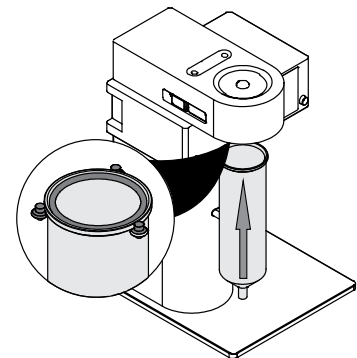

- ▶ Make sure, that the connection for the outlet sensor shows in the direction indicated.
- ▶ Turn the spray cylinder that the coupling flange fits the adjustment.

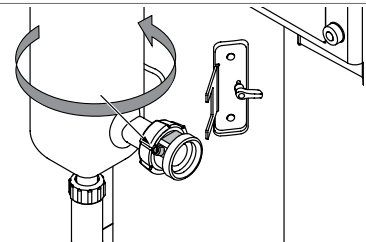

- ▶ Close the handle.

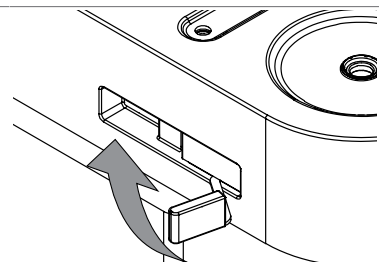

- ▶ Fix the handle at the adjustment.

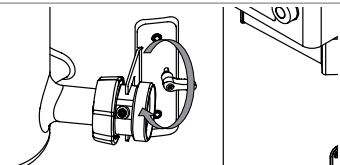



Precondition:

- ☑ The product collection vessel is prepared. See Chapter 7.3 "Preparing the product vessel", page 41

- ▶ Attach the cyclone to the spray cylinder.

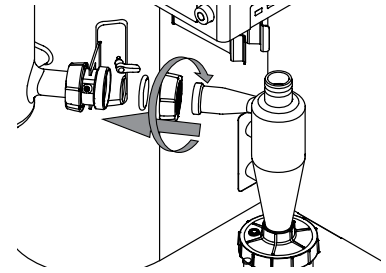

- ▶ Attach the cyclone to the filter.

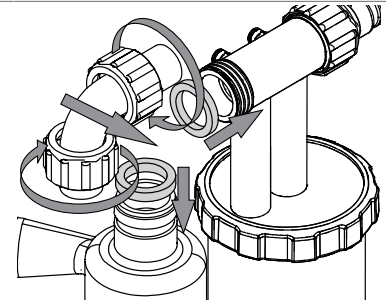

### 7.3 Preparing the product vessel



#### NOTE

Removing is done in reverse sequence.

- ▶ Prepare the product collection vessel.

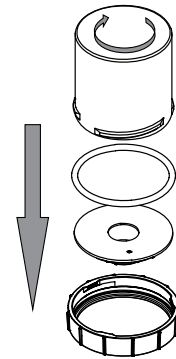

- ▶ Attach the prepared product vessel to the cyclone.

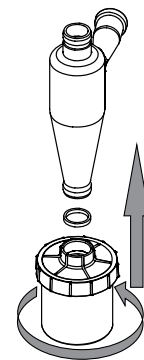

### 7.4 Preparing the spray drying nozzle

Attaching and removing hoses to the nozzle:

- ▶ Press the ring at the connector.
- ▶ Move the hose.

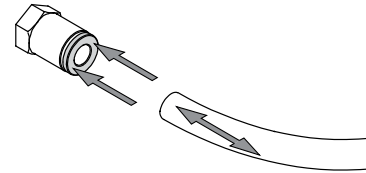

Precondition:

- ☑ The peristaltic pump is prepared. See Chapter 7.5 "Preparing the peristaltic pump", page 43
- ▶ Insert the nozzle into the heater element of the spray dryer.

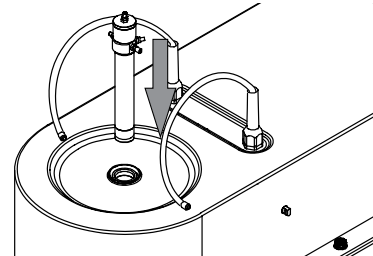

- ▶ Attach the spray gas onto the connection marked **GAS**.
- ▶ Attach the inlet tube in place with the union nut.

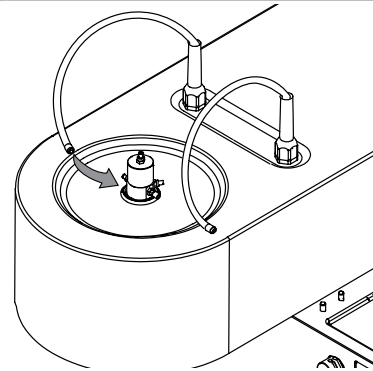

- ▶ Attach the compressed gas to the nozzle.

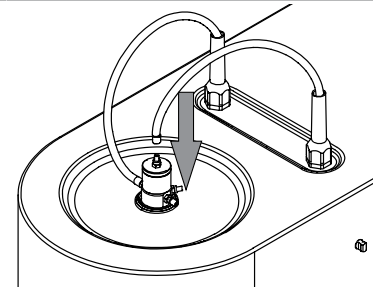

- ▶ Attach the assembled feeding tube onto the connection marked **FEED**.
- ▶ Attach the inlet tube in place with the union nut.

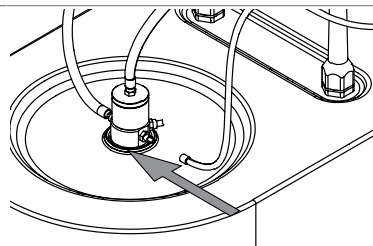

## 7.5 Preparing the peristaltic pump

### 7.5.1 Preparing the peristaltic pump for manual mode

Precondition:

The peristaltic pump bed is prepared. See Chapter 7.8 "Adjusting the peristaltic pump bed", page 46

The solvent is prepared.

Sample is prepared.

▶ Prepare the feeding tube.

▶ Lower the hose base.

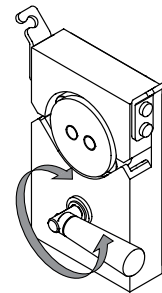
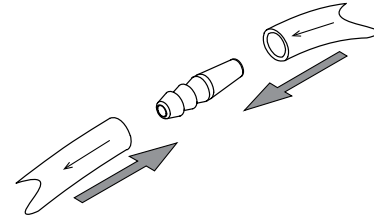

▶ Install the feeding tube.

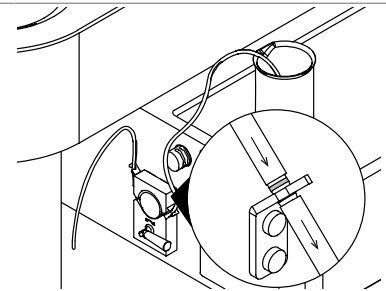

▶ Close the hose base.

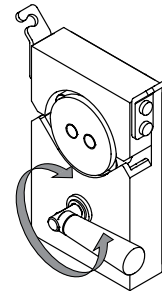

### 7.5.2 Preparing the peristaltic pump for auto mode (option)

Precondition:

The peristaltic pump bed is prepared. See Chapter 7.8 "Adjusting the peristaltic pump bed", page 46

The solvent is prepared.

Sample is prepared.

▶ Prepare the Y-piece.

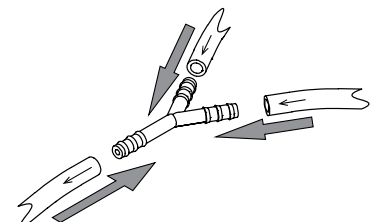

- ▶ Lower the hose base.

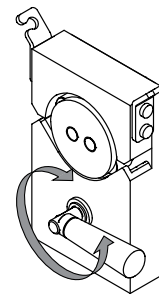

- ▶ Attach the tube with the sample in the rear guide.
- ▶ Attach the tube with the solvent in the front guide.

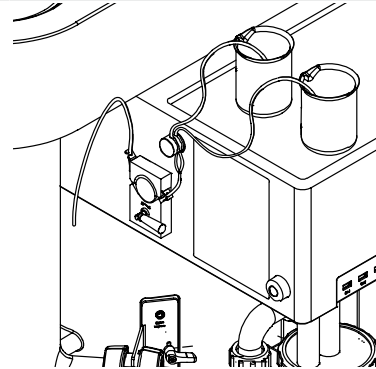

- ▶ Close the hose base.

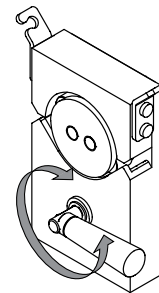

- ▶ Connect the feeding tube to the nozzle. See Chapter 7.4 "Preparing the spray drying nozzle", page 41

## 7.6 Preparing the sensors

### 7.6.1 Preparing the product temperature sensor (option)

(first time only)

- ▶ Remove the cap nut from the product collection vessel.

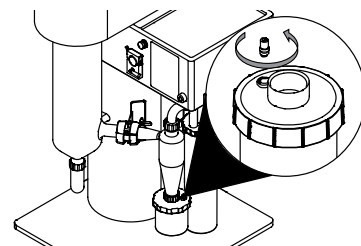

(first time only)

- ▶ Remove the sealing from the cap nut.

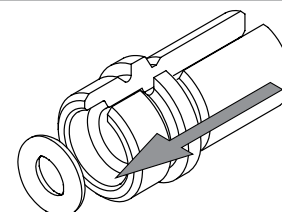

(first time only)

- ▶ Attach the sealing to the sensor.

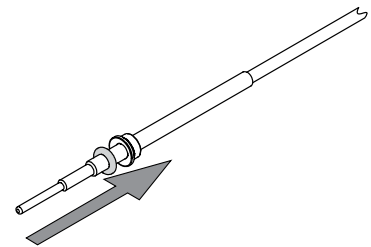

- ▶ Attach the cap nut to the sensor.

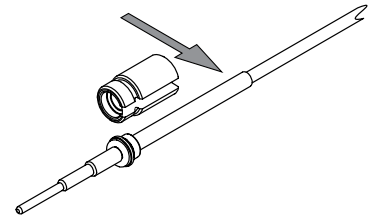

- ▶ Attach the sensor to the product collection vessel.

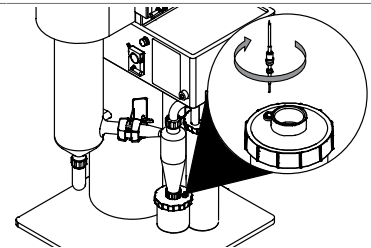

- ▶ Connect the sensor to the instrument.

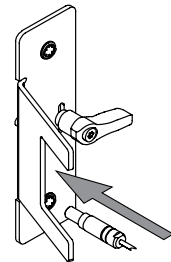

## 7.6.2 Preparing the outlet temperature sensor

(first time only)

- ▶ Remove the cap nut from the sensor mounting.

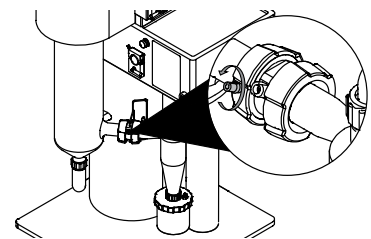

(first time only)

- ▶ Remove the sealing from the cap nut.

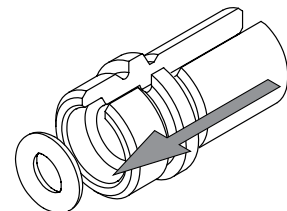

(first time only)

- ▶ Attach the sealing to the sensor.

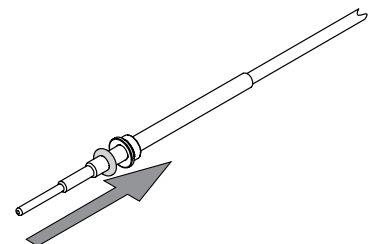

- ▶ Attach the cap nut to the sensor.

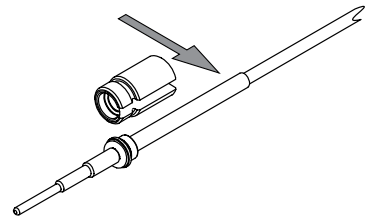

- ▶ Attach the sensor to the sensor mounting.

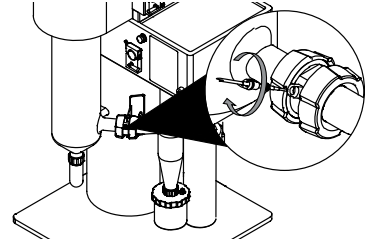

- ▶ Connect the sensor to the instrument.

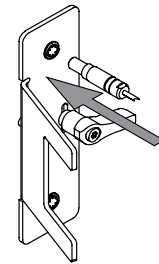

## 7.7 Preparing the grounding (if no product sensor is used)

- ▶ Attach the grounding cable to the product collection vessel.

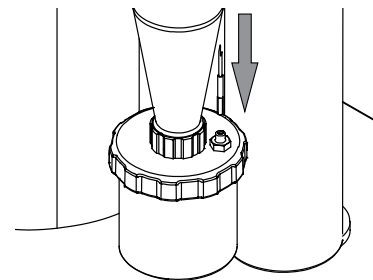

- ▶ Connect the grounding cable to the instrument.

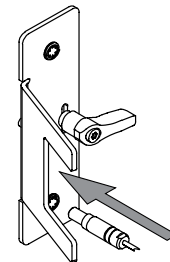

## 7.8 Adjusting the peristaltic pump bed

Tools needed:

	Order no.	Image
Torx size 15	none	

### Navigation path



- ▶ Select a suitable feeding tube. See Chapter 12.1.1 "Feeding tube", page 75
- ▶ Prepare the solvent.
- ▶ Lower the hose base.

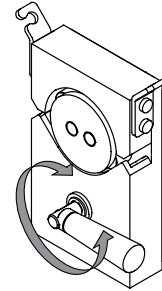

- ▶ Install the feeding tube.
- ▶ Put the other end of the tube in a n beaker flask.

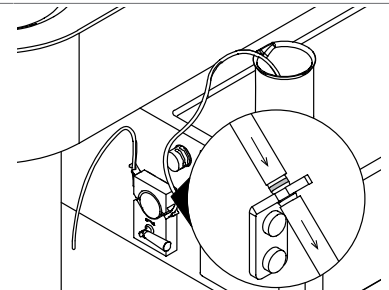

- ▶ Close the hose base.

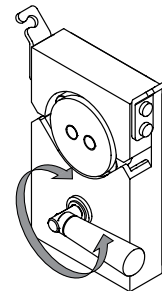

- ▶ Navigate to the *Control panel* according the navigation path.
- ▶ Tab the Start peristaltic pump button.
- ▶ Close the pump bed that no liquid can pass.
- ▶ Turn the key 1/4 the opposite side.
- ▶ Calibrate the peristaltic pump. See Chapter 9.2 "Calibrating the peristaltic pumps", page 63

## 7.9 Preparing the instrument for remote services (option)



### NOTE

Press the *[Take Back Control]* button on the display to interrupt the connection to the mobile device.

There are two remote services available:

Remote type	Explanation
[Remote Control]	Carrying out the instrument functions from a remote device.
[Monitoring]	Monitoring all values from a remote device.

#### Navigation path:



#### Precondition:

- ☑ The instrument and the mobile device are prepared. See Chapter 5.6 "Installations for remote services (option)", page 26
- ▶ Tap the [Start Remote] button on the instrument.
- ▶ Select the remote service on the app.
- ⇒ The instrument and the app are connected.

## 7.10 Editing a method (Advanced and Corrosive only)

### 7.10.1 Creating a new method



#### NOTE

It is not possible to enter a name twice.

#### Creating a new method

##### Navigation path



- ▶ Navigate to the *Methods* menu according to the navigation path.
- ▶ Tap the [ + ] button.
- ▶ Select the [Name] action.
- ⇒ The display shows a dialog with an alphanumeric input box.
- ▶ Enter a name for the method.
- ▶ Tap the [Save] button.
- ⇒ The method is created.

#### Creating a new method by copying an existing

##### Navigation path



- ▶ Navigate to the *Methods* menu according to the navigation path.
- ▶ Tap the [Options] button.
- ▶ Tap the [Duplicate] action.
- ▶ Select the method you wish to copy.
- ▶ Tap the [Duplicate] button.
- ⇒ The copy is created.



## 7.10.2 Deleting a method

### Navigation path

---



- ▶ Navigate to the *Methods* menu according to the navigation path.
- ▶ Tap the *[Options]* button.
- ▶ Tap the *[Delete]* action.
- ▶ Select the method you wish to delete.
- ▶ Tap the *[Delete]* button.
- ⇒ The method is deleted.

## 7.10.3 Changing the name of a method

### Navigation path

---



Precondition:

- The method is not loaded.
- ▶ Navigate to the *Methods* menu according to the navigation path.
- ▶ Select the method you wish to edit.
- ▶ Select the *Basic Information* section.
- ▶ Select the action *[Name]*.
- ⇒ The display shows a dialog with an alphanumeric input box.
- ▶ Enter a name for the method.
- ▶ Tap the *[Save]* button.
- ⇒ The method name is changed.

## 7.10.4 Changing the description for a method

### Navigation path

---



Precondition:

- The method is not loaded.
- ▶ Navigate to the *Methods* menu according to the navigation path.
- ▶ Select the method you wish to edit.
- ▶ Select the *Basic Information* section.
- ▶ Select the *[Description]* action.
- ⇒ The display shows a dialog with an alphanumeric input box.
- ▶ Enter a description for the method.
- ▶ Tap the *[Save]* button.
- ⇒ The description for the method is saved.

### 7.10.5 Changing the drying gas volume for a method

#### Navigation path

---



Precondition:

- The method is not loaded.
- ▶ Navigate to the *Methods* menu according to the navigation path.
- ▶ Select the method you wish to edit.
- ▶ Select the *Method Parameters* section.
- ▶ Select the *[Drying Gas]* action.
  - ⇒ The display shows a dialog box with a numeric input box.
- ▶ Enter the drying gas volume in m<sup>3</sup>/h.
- ▶ Tab the *[Save]* button.
- ⇒ The drying gas volume is saved.

### 7.10.6 Changing the inlet temperature for a method

#### Navigation path

---



Precondition:

- The method is not loaded.
- ▶ Navigate to the *Methods* menu according to the navigation path.
- ▶ Select the method you wish to edit.
- ▶ Select the *Method Parameters* section.
  - ⇒ The display shows a dialog box with a numeric input box.
- ▶ Select the *[Inlet Temperature]* action.
- ▶ Enter the target value in °C.
- ▶ Tab the *[Save]* button.
- ⇒ The inlet temperature is saved.

### 7.10.7 Changing the dispersion gas volume for a method

#### Navigation path

---



- ▶ Navigate to the *Methods* menu according to the navigation path.
- ▶ Select the method you wish to edit.
- ▶ Select the *Method Parameters* section.
- ▶ Select the *[Dispersion Gas]* action.
- ▶ Enter the target dispersion gas volume L/h.
  - ⇒ The display shows a dialog box with a numeric input box.
- ▶ Tab the *[Save]* button.
- ⇒ The dispersion gas volume is saved.

## 7.10.8 Changing the pump volume for a method

### Navigation path

---



- ▶ Navigate to the *Methods* menu according to the navigation path.
- ▶ Select the method you wish to edit.
- ▶ Select the *Method Parameters* section.
  - ⇒ The display shows a dialog box with a numeric input box.
- ▶ Select the *[Pump]* action.
- ▶ Enter the pump volume in mL/min.
- ▶ Tab the *[Save]* button.
  - ⇒ The pump volume is saved.

## 7.10.9 Changing the outlet temperature for a method

This action sets the alarm value for the outlet temperature.  
The instrument does not carry out any additional actions.

### Navigation path

---



- ▶ Navigate to the *Methods* menu according to the navigation path.
- ▶ Select the method you wish to edit.
- ▶ Select the *Method parameters* section.
- ▶ Select the *[Outlet Temp. Alarm]* action.
  - ⇒ The display shows a dialog box with a numeric input box.
- ▶ Enter the outlet temperature in °C.
- ▶ Tab the *[Save]* button.
  - ⇒ The outlet temperature is saved.

## 7.10.1 Changing the product temperature for a method

0

This action sets the alarm value for the product temperature.  
The instrument does not carry out any additional actions.

### Navigation path

---



- ▶ Navigate to the *Methods* menu according to the navigation path.
- ▶ Select the method you wish to edit.
- ▶ Select the *Method parameters* section.
- ▶ Select the *[Product Temp. Alarm]* action.
  - ⇒ The display shows a dialog box with a numeric input box.
- ▶ Enter the product temperature in °C.
- ▶ Tab the *[Save]* button.
  - ⇒ The product temperature is saved.

### 7.10.1 Changing the nozzle deblock frequency for method

1

#### Navigation path

---



- ▶ Navigate to the *Methods* menu according to the navigation path.
- ▶ Select the method you wish to edit.
- ▶ Select the *Method parameters* section.
- ▶ Select the *[Deblock Nozzle]* action.
  - ⇒ The display shows a dialog box with a numeric input box.
- ▶ Enter the deblock speed in bpm.
- ▶ Tap the *[Save]* button.
  - ⇒ The deblock speed of the nozzle is saved.

### 7.10.1 Importing a method

2

the following method format is possible:

- .bdmf

#### Navigation path

---



Precondition:

- A data storage device with a method is connected to the instrument.
- ▶ Navigate to the *Methods* menu according to the navigation path.
- ▶ Tap the *[Options]* button.
- ▶ Tap the *[Import]* action.
- ▶ Select the method you wish to import.
  - ⇒ A dialog confirms the method import.

### 7.10.1 Exporting a method

3

#### Navigation path

---



Precondition:

- A data storage device is connected to the instrument.
- ▶ Navigate to the *Methods* menu according to the navigation path.
- ▶ Tap the *[Options]* button.
- ▶ Select the *[Export]* action.
- ▶ Select the method you wish to export.
- ▶ Tap the *[Export]* button.
- ▶ Select the export folder.
  - ⇒ A message confirms the method export.

## 7.10.1 Loading a method

4

### Navigation path

---



Precondition:

- A method is created. See Chapter 7.10 "Editing a method (Advanced and Corrosive only)", page 48
- ▶ Navigate to the *Methods* menu according to the navigation path.
- ▶ Tap the load method button for the method you wish to use.
  - ⇒ The method is loaded.

## 7.11 Editing a job list (Advanced and Corrosive only)



### NOTE

It is not possible to enter a name twice.

### 7.11.1 Creating a new job list

#### Navigation path

---



- ▶ Navigate to the *Job Lists* panel.
- ▶ Tap the [ + ] button.
- ▶ Select the [Name] action.
  - ⇒ The display shows a dialog with an alphanumeric input box.
- ▶ Select a method for the job list.
- ▶ Enter a name for the job list entry.
- ▶ Tap the [Save] button.
  - ⇒ The job list is created.

### 7.11.2 Adding an entry to a job list

#### Adding an entry to a job list

#### Navigation path

---



- ▶ Navigate to the *Job Lists* panel.
- ▶ Select the job list which you want to add an entry.
- ▶ Tap the [ + ] button.
  - ⇒ The display shows a dialog with an alphanumeric input box.
- ▶ Enter a name for the job list entry.
- ▶ Select a method for the job list entry.
- ▶ Enter a description for the entry.
- ▶ Tap the [Save] button.
  - ⇒ The job list is created.

## Adding an entry to a job list by copy an existing

### Navigation path

---



- ▶ Navigate to the *Job Lists* panel.
  - ▶ Select the job list which you want to add an entry.
  - ▶ Select the job list entry you wish to copy.
  - ▶ Tap the *[Copy]* button.
  - ▶ Tap the *[Save]* button.
- ⇒ A message confirms the job list entry.

### 7.11.3 Deleting a job list

#### Navigation path

---



- ▶ Navigate to the *Job Lists* panel.
  - ▶ Tap the *[Options]* button.
  - ▶ Tap the *[Delete]* action.
  - ▶ Select the job list you wish to delete.
  - ▶ Tap the *[Delete]* button.
- ⇒ The job list is deleted.

### 7.11.4 Deleting a job list entry

#### Navigation path

---



- ▶ Navigate to the *Job Lists* panel.
  - ▶ Select the job list in which you want to delete an entry.
  - ▶ Select the job list entry you wish to delete.
  - ▶ Tap the *[Delete]* button.
  - ▶ Tap the *[Save]* button.
- ⇒ A message confirms the job list entry.

### 7.11.5 Loading a job list

#### Navigation path

---



Precondition:

- A job list is created. See Chapter 7.11 "Editing a job list (Advanced and Corrosive only)", page 53
  - ▶ Navigate to the *Job Lists* panel.
  - ▶ Tap the load button for the job list you wish to use.
- ⇒ The job list is loaded.

## 7.12 Editing an auto mode sequence (Advanced and Corrosive only)

The following functions are programmable:

Function	Description
[Pump 1]	Select between detection and flow volume. Start the spray process.
[Remaining Volume of Solvent]	Enter the volume of pure solvent to be transported before switching to the sample.
[Remaining Volume of Sample]	Enter the volume of sample to be transported before switching back to the pure solvent.
[Auto Mode State]	Select a spray drying phase. Selection possibilities depends on the instrument status.



- ▶ Navigate to the *Auto sequence* action according the navigation path.
  - ▶ Enter the requested values.
  - ▶ Select the [Auto Mode State] you wish to use.
  - ▶ Tap the [Start] button.
- ⇒ The instrument starts a spray drying process with the set parameters.

## 7.13 Tagging table entries

A tag is keyword assigned to a table entry. This helps to describe an entry better and allows it to be found again by browsing or searching.

- ▶ Select the table entry you wish to tag.
  - ▶ Select the *Basic Information* section.
  - ▶ Select the [Tags] action.
  - ▶ Tap the [ + ] button.
- ⇒ The display shows a dialog with an alphanumeric input box.
- ▶ Enter a name for the tag.
  - ▶ Tap the [Save] button.
- ⇒ The list entry is tagged.

## 8 Carrying out a spray drying process



### NOTE

To minimizing negative environmental affects during operation:

- ▶ Follow the instructions in the corresponding "*Application Note*".

### 8.1 Preparing the instrument for monitoring

Navigation path:



Precondition:

- The instrument and the mobile device are prepared. See Chapter 5.6 "*Installations for remote services (option)*", page 26
- ▶ Tap the [*Monitor*] button on the app.

### 8.2 Carrying out a spray drying process in open mode

#### 8.2.1 Preparing the instrument for open mode

Precondition:

- All commissioning operations have been completed. See Chapter 5 "*Installation*", page 25
- A configuration for the open mode is installed. See related "*Installation Manual*"
- ▶ Set the On/Off master switch to on.
  - ⇒ The instrument is starting up.
- ▶ Prepare the pure solvent.
- ▶ Prepare the sample.
- ▶ Place sample and solvent on the sample place area.
- ▶ Prepare the peristaltic pump. See Chapter 7.5 "*Preparing the peristaltic pump*", page 43
- ▶ Prepare the spray drying nozzle. See Chapter 7.4 "*Preparing the spray drying nozzle*", page 41
- ▶ Make sure that the tubing is not bend.
- ▶ Make sure that no defective sealings or glass parts are used.
- ▶ Prepare the glass assembly. See Chapter 7.2 "*Preparing the glass assembly*", page 39

#### 8.2.2 Starting a spray drying process in open mode

Start the spray drying process according to your needs:

- Chapter "*Starting a spray drying process in open mode manually*", page 57
- Chapter "*Starting a spray drying process in open auto mode (Advanced and Corrosive only)*", page 57



## Starting a spray drying process in open mode manually



### NOTE

- ▶ There are three possibilities to carry out the manual mode:
  - ⇒ Carrying out each parameter individually.
  - ⇒ With a method. See Chapter 7.10 "Editing a method (Advanced and Corrosive only)", page 48
  - ⇒ With a job list. See Chapter 7.11 "Editing a job list (Advanced and Corrosive only)", page 53

### Navigation path

---



Precondition:

- The instrument is prepared. See Chapter 8.2.1 "Preparing the instrument for open mode", page 56
- ▶ If necessary, load a method. See Chapter 7.10.14 "Loading a method", page 53
- ▶ If necessary, load a job list. See Chapter 7.11.5 "Loading a job list", page 54
- ▶ Navigate to the *Control panel* according the navigation path.
- ▶ If necessary, adjust the drying gas volume.
- ▶ Tap the drying gas start button.
  - ⇒ The aspirator is starting up.
- ▶ If necessary, adjust the spray gas volume.
- ▶ Tap the spray gas start button.
- ▶ If necessary, adjust the inlet temperature.
- ▶ Tap the inlet temperature start button.
  - ⇒ The instrument is heating up.
- ▶ Wait until the system is in steady conditions.
- ▶ Immerse the tube in the solvent.
- ▶ If necessary, adjust the peristaltic pump volume.
- ▶ Tap the peristaltic pump start button.
  - ⇒ The solvent flows to the nozzle.

## Starting a spray drying process in open auto mode (Advanced and Corrosive only)



### NOTE

- ▶ There are three possibilities to carry out the auto mode:
  - ⇒ With an auto mode sequence. See Chapter 7.12 "Editing an auto mode sequence (Advanced and Corrosive only)", page 55
  - ⇒ With a method. See Chapter 7.10 "Editing a method (Advanced and Corrosive only)", page 48
  - ⇒ With a job list. See Chapter 7.11 "Editing a job list (Advanced and Corrosive only)", page 53

### Navigation path

---



Precondition:

- The instrument is prepared. See Chapter 8.2.1 "Preparing the instrument for open mode", page 56
- ▶ If necessary, edit the auto mode sequence. See Chapter 7.12 "Editing an auto mode sequence (Advanced and Corrosive only)", page 55
- ▶ If necessary, load a method. See Chapter 7.10.14 "Loading a method", page 53
- ▶ If necessary, load a job list. See Chapter 7.11.5 "Loading a job list", page 54
- ▶ Navigate to the *Control panel* according the navigation path.
- ▶ Tap the drying gas start button.
- ⇒ The instrument starts the auto mode.

### 8.2.3 Tasks during spray drying (manual mode only)

Precondition:

- The instrument is in operating conditions. See Chapter 8.2.2 "Starting a spray drying process in open mode", page 56
- ▶ Change the feed tube from the pure solvent to the sample.
- ⇒ The sample flows through the feed tube to the nozzle.

### 8.2.4 Ending a spray drying process in open mode

Precondition:

- The sample beaker is empty.
- ▶ Change the feed tube from the sample to the solvent.
- ▶ Wait 2 -3 minutes.
- ⇒ The solvent flushes the remains from the nozzle.
- ▶ Remove the sample tube from the solvent vessel.
- ▶ Wait until the tube is empty.
- ▶ Tap the peristaltic pump stop button.
- ▶ Tap the spray gas stop button.
- ▶ Tap the heater stop button.
- ▶ If necessary save the run.
- ▶ Wait until the glassware is in ambient temperature.
- ▶ Tap the aspirator stop button.
- ▶ Remove the product from the product collection vessel.

### 8.2.5 Shutting down the instrument

Precondition:

- The spray drying process is finished. See Chapter 8.2.4 "Ending a spray drying process in open mode", page 58
- ▶ Switch the On/Off master switch to Off.
- ▶ Clean the nozzle. See Cleaning and servicing

## 8.3 Carrying out a spray drying process in closed mode

There are two different modes closed mode:

- Closed mode with inert loop
- Closed mode with inert loop and dehumidifier

### 8.3.1 Preparing the instrument for closed mode

	Low drying temperature ca. 80 °C	High drying temperature ca. 220 °C
Time required:	approx. 15 min	approx. 30 min

Precondition:

- All commissioning operations have been completed. See Chapter 5 "Installation", page 25
- A configuration for the closed mode is installed. See related "*Installation Manual*"
  - ▶ Set the On/Off master switch to On.
    - ⇒ The instrument is starting up.
  - ▶ Prepare pure solvent.
  - ▶ Prepare the sample.
  - ▶ Place sample and solvent on the sample place area.
  - ▶ Prepare the peristaltic pump. See Chapter 7.5 "Preparing the peristaltic pump", page 43
  - ▶ Prepare the spray drying nozzle. See Chapter 7.4 "Preparing the spray drying nozzle", page 41
  - ▶ Make sure that no defective sealings or glass parts are used.
  - ▶ Make sure that the tubing is not bend.
  - ▶ Prepare the glass assembly. See Chapter 7.2 "Preparing the glass assembly", page 39

### 8.3.2 Starting a spray drying process in closed mode

#### Starting a spray drying process in closed auto mode (Advanced and Corrosive only)



#### NOTE

- ▶ There are three possibilities to carry out the auto mode:
  - ⇒ With an auto mode sequence. See Chapter 7.12 "Editing an auto mode sequence (Advanced and Corrosive only)", page 55
  - ⇒ With a method. See Chapter 7.10 "Editing a method (Advanced and Corrosive only)", page 48
  - ⇒ With a job list. See Chapter 7.11 "Editing a job list (Advanced and Corrosive only)", page 53

#### Navigation path



**Precondition:**

- ☑ The instrument is prepared. See Chapter 8.3.1 "Preparing the instrument for closed mode", page 59
- ▶ Select the condenser temperature at the Inert Loop.
- ▶ For closed mode with inert loop and dehumidifier set the On/Off master switch of the dehumidifier to on.
- ▶ If necessary, edit the auto mode sequence. See Chapter 7.12 "Editing an auto mode sequence (Advanced and Corrosive only)", page 55
- ▶ If necessary, load a method. See Chapter 7.10.14 "Loading a method", page 53
- ▶ If necessary, load a job list. See Chapter 7.11.5 "Loading a job list", page 54
- ▶ Navigate to the *Control panel* according the navigation path.
- ▶ Tap the drying gas start button.
- ⇒ The instrument starts the auto mode.

**Starting a spray drying process in closed mode manually****NOTE**

- ▶ There are three possibilities to carry out the manual mode:
  - ⇒ Carrying out each parameter individually.
  - ⇒ With a method. See Chapter 7.10 "Editing a method (Advanced and Corrosive only)", page 48
  - ⇒ With a job list. See Chapter 7.11 "Editing a job list (Advanced and Corrosive only)", page 53

**Navigation path****Precondition:**

- ☑ The instrument is prepared. See Chapter 8.3.1 "Preparing the instrument for closed mode", page 59
- ▶ Select the condenser temperature at the Inert Loop.
- ▶ For closed mode with inert loop and dehumidifier set the On/Off master switch of the dehumidifier to On.
- ▶ If necessary, load a method. See Chapter 7.10.14 "Loading a method", page 53
- ▶ If necessary, load a job list. See Chapter 7.11.5 "Loading a job list", page 54
- ▶ Navigate to the *Control panel* according the navigation path.
- ▶ If necessary, adjust the drying gas volume.
- ▶ Tap the drying gas start button.
- ⇒ The aspirator is starting up.
- ⇒ The oxygen level decreases.
- ⇒ The spray gas starts.
- ▶ Wait until the oxygen level is less than 6%.
- ▶ If necessary, adjust the inlet temperature.
- ▶ Tap the inlet temperature start button.
- ⇒ The instrument is heating up.
- ▶ Wait until the system is in steady conditions.

- ▶ Immerse the tube in the solvent.
  - ▶ If necessary, adjust the peristaltic pump volume.
  - ▶ Tap the peristaltic pump start button.
- ⇒ The solvent flows to the nozzle.

### 8.3.3 Tasks during spray drying (manual mode only)

Precondition:

- The instrument is in operating conditions. See Chapter 8.3.2 "Starting a spray drying process in closed mode", page 59
  - ▶ Change the feed tube from the pure solvent to the sample.
- ⇒ The sample flows through the feed tube to the nozzle.

### 8.3.4 Ending a spray drying process in closed mode

Precondition:

- The sample beaker is empty.
  - ▶ Change the feed tube from the sample to the pure solvent.
  - ▶ Decrease the pump rate.
  - ▶ Wait 2 -3 minutes.
- ⇒ The solvent flushes the remains from the nozzle.
- ▶ Remove the sample tube from the solvent vessel.
  - ▶ Wait until the tube is empty.
  - ▶ Tap the peristaltic pump stop button.
  - ▶ Tap the heater stop button.
  - ▶ If necessary save the run.
  - ▶ Wait until the glassware is in ambient temperature.
  - ▶ Tap the aspirator stop button.
  - ▶ Set the air flow to 0.
  - ▶ Remove the product from the product collection vessel.

### 8.3.5 Shutting down the instrument

Precondition:

- The spray drying process is finished. See Chapter 8.3.4 "Ending a spray drying process in closed mode", page 61
- ▶ Switch the On/Off master switch to Off.
- ▶ For closed mode with inert loop and dehumidifier set the On/Off master switch of the dehumidifier to Off.
- ▶ Clean the nozzle. See Cleaning and servicing

## 8.4 Exporting run data

- .csv
- .pdf

Navigation path



Precondition:

- ☑ A data storage device is connected to the instrument.
- ▶ Navigate to the *Runs* panel according the navigation path.
- ▶ Tap the *[Options]* button.
- ▶ Select the export format you wish to use.
- ▶ Select the run you wish to export.
- ▶ Tap the *[Export]* button.
- ▶ Select the export folder.
- ⇒ A message confirms the run export.

## 8.5 Deleting run data

Navigation path

---



- 
- ▶ Navigate to the *Runs* panel according the navigation path.
  - ▶ Tap the *[Options]* button.
  - ▶ Tap the *[Delete]* action.
  - ▶ Select the run you wish to delete.
  - ▶ Tap the *[Delete]* button.
  - ⇒ The run is deleted.

## 8.6 Disconnecting the remote services

Precondition:

- ☑ The display shows the *[Take Back Control]* button.
- ▶ Tap the *[Take Back Control]* button.

## 9 Cleaning and servicing



### NOTE

- ▶ Carry out only the service and cleaning operations described in this section.
- ▶ Do not carry out any servicing and cleaning operations that involve opening the housing.
- ▶ Use only genuine BUCHI spare parts in order to ensure correct operation and preserve the warranty.
- ▶ Carry out the service and cleaning operations described in this section to extend the lifetime of the instrument.

### 9.1 Regular maintenance work

Action	Daily	Weekly	Additional information
9.2 Calibrating the peristaltic pumps	1		Calibrate the peristaltic pumps before every use.
9.9 Cleaning the glass component	1		Carry out this action after every instrument use.
9.10 Cleaning the nozzle	1		Clean the spray drying nozzle after every use.
9.6 Cleaning and servicing the drying gas hoses		1	
9.7 Cleaning the filter		1	
9.3 Cleaning the aspirator		2	
9.11 Cleaning and servicing the warning and directive symbols		2	
9.12 Cleaning the housing		2	

1 - User; 2 - Operator

### 9.2 Calibrating the peristaltic pumps

#### Navigation path



#### Precondition:

- The peristaltic pump is prepared. Chapter 7.5 "Preparing the peristaltic pump", page 43
- A measuring cylinder is available.
- A calibration sample with the same viscosity as the sample is available.
- ▶ Fill the tube with the calibration sample.
- ▶ Put the sample feeding tube in the calibration sample.
- ▶ Put the other end in the measuring cylinder.

- ▶ Navigate to the *Maintenance* submenu via the navigation path.
- ▶ Remove the air bubbles.
- ▶ Enter the necessary calibration volume.
- ▶ Enter the necessary calibration time.
- ▶ Tap the *[Start Calibration]* button.
- ▶ Wait until the calibration time is over.
- ▶ Enter the difference between target value and actual value.

### 9.3 Cleaning the aspirator



#### NOTE

Do not immerse the tube into the water.

Be aware that no splashes are contaminating the ambient at the outlet side.

#### Navigation path

---



- ▶ Fill a vessel with 2L water.
- ▶ Prepare an empty canister with a small opening.
- ▶ Insert the exhaust tube from the aspirator into one third of the empty canister.
- ▶ Remove the spray gas supply.
- ▶ Fix the tube.
- ▶ Set the aspirator to 20 m<sup>3</sup>/h.
- ▶ Set the aspirator to on.
- ▶ Carefully move the inlet tube over the surface of the water to suck in a mixture of air and water.
- ▶ Increase the aspirator rate up to 28 m<sup>3</sup>/h.
- ▶ Continue this procedure unless clean water is coming out of the aspirator.
- ▶ Wait until the aspirator is dry.
- ▶ Navigate to the *Control* panel according the navigation path.
- ▶ Set the drying gas to the necessary volume.
- ▶ Tap the drying gas start button.
- ⇒ The aspirator is starting up.
- ▶ Wait until the aspirator is dry.

### 9.4 Opening and closing the lower rear door.

- ▶ Push the snap lock down and pull the door.

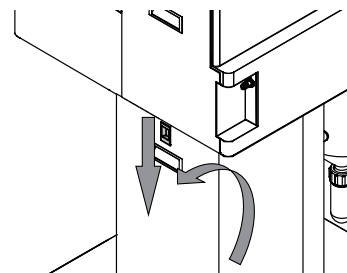



- ▶ Remove the exhaust air hose.

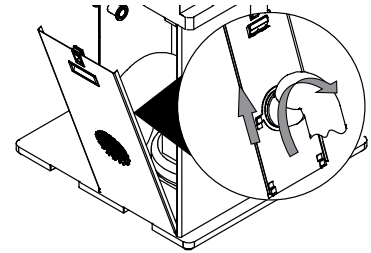

- ▶ Remove the door.

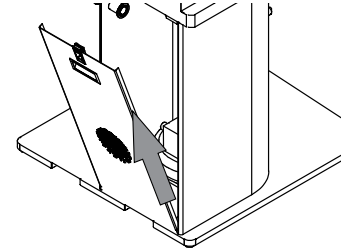

## 9.5 Opening and closing the upper rear door

- ▶ Push the snap lock down and pull the door.

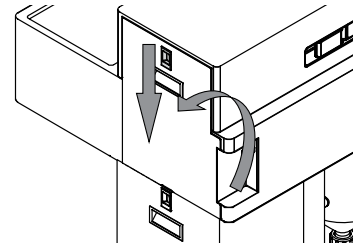

- ▶ Remove the door.

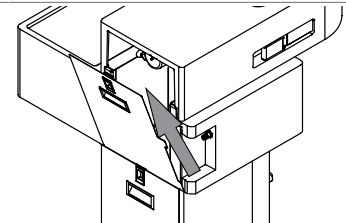

## 9.6 Cleaning and servicing the drying gas hoses

### Navigation path



- ▶ Check the hoses for degradation.
  - ⇒ If necessary replace them.
- ▶ Remove all hoses from the instrument.
- ▶ Rinse the hoses with water.
- ▶ Install the hoses according the related installation manual.
- ▶ Navigate to the *Control* panel according the navigation path.
- ▶ Set the drying gas to the necessary volume.
- ▶ Tap the drying gas start button.
  - ⇒ The aspirator is starting up.
- ▶ Wait until the hoses are dry.
- ▶ Tap the stop button.

## 9.7 Cleaning the filter

- ▶ Check if the outlet filter pressure is not more than 20 mbar relative to the clean filter.
- ▶ If necessary, clean or replace the filter. See Chapter 7.1 "Preparing the outlet filter", page 36

## 9.8 Cleaning the heater



### NOTE

Installing is done in reverse sequence.

Precondition:

- The instrument is not connected to the electric grid.
- ▶ Wait until the heater is in ambient temperature.
- ▶ Open the upper rear door. See Chapter 9.5 "Opening and closing the upper rear door", page 65
- ▶ Disconnect the plug.
- ▶ Open the screw from the heater.
- ▶ Remove the heating element.

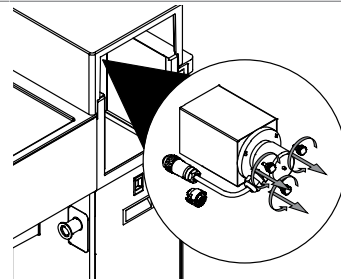
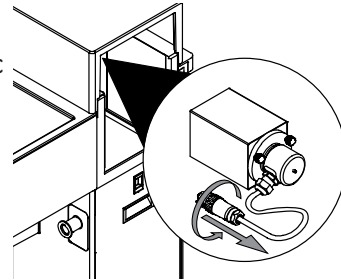

- ▶ Brush the heating element.

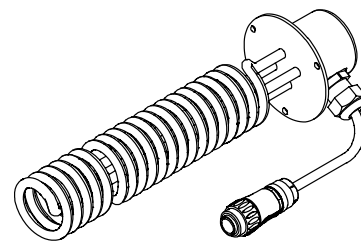

## 9.9 Cleaning the glass component

- ▶ Check the glass ware for mechanical defects.
  - ⇒ If necessary, replace them.
- ▶ Check the glass ware for residues.
- ▶ Check the glass wall of the main body and the connectors.
  - ⇒ If the part is dirty, clean it with detergents.
  - ⇒ If the glass part is showing deterioration or leakages, replace it.

## 9.10 Cleaning the nozzle



### NOTICE

#### Sharp cleaning tools

Sharp cleaning tools can damage the surface.

- ▶ Do not use any sharp cleaning tools.



### NOTICE

#### Liquids in cooling gas channels.

Liquids in cooling gas channels cause damage.

- ▶ Make sure that no liquids get into the cooling gas channels during the cleaning process.
- ▶ Remove the cleaning head.

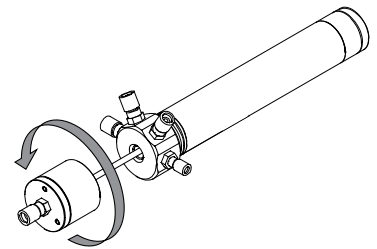

- ▶ Remove the nozzle cap.

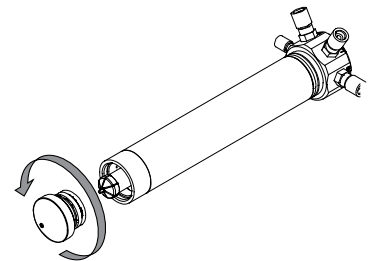

- ▶ Remove the nozzle tip.

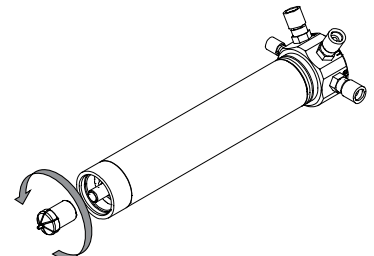

- ▶ Clean the nozzle with a small cleaning brush, cleaning agent and water.

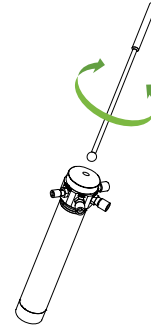

- ▶ Clean the with a damp cloth, leaning agent and water.

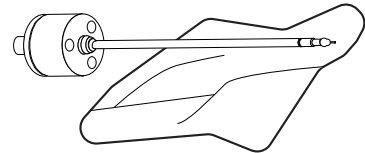

### 9.11 Cleaning and servicing the warning and directive symbols

- ▶ Check that the warning symbols on the instrument are legible.
- ▶ If they are dirty, clean them.

### 9.12 Cleaning the housing

- ▶ Wipe down the housing with a damp cloth.
- ▶ If heavily soiled, use ethanol or a mild detergent.
- ▶ Wipe down the display with a damp cloth.

## 10 Help with faults

### 10.1 Troubleshooting

#### 10.1.1 Troubleshooting general

Problem	Possible cause	Action
Instrument cannot be switched on.	No electric connection.	▶ Establish an electrical connection. See Chapter 5.2 "Establishing electrical connections", page 25
Peristaltic pump does not apply solvent.	The rollers are not in contact with the running surface.	▶ Lift the hose base. ▶ Adjust the peristaltic pump bed. See Chapter 7.8 "Adjusting the peristaltic pump bed", page 46
	Feed tube defective.	▶ Replace the feed tube.
Product is delivered after the spray flow is switched on although the pump is switched off.	The pressure of the rollers on the running surface is too weak.	▶ Adjust the peristaltic pump bed. See Chapter 7.8 "Adjusting the peristaltic pump bed", page 46
Nozzle is block.	Product is too concentrated.	▶ Use a lower concentration in pump.
	Encrustation on nozzle exit.	▶ Clean the nozzle. See Chapter 9.10 "Cleaning the nozzle", page 67
	Nozzle is defective (e.g. bent nozzle needle).	▶ Replace nozzle or defective part.
Irregular or pulsed spraying.	Leaks in the spray nozzle.	▶ Check seals in the spray nozzle. ▶ If necessary, replace the seals.
		Product drips in spray chamber.

<b>Problem</b>	<b>Possible cause</b>	<b>Action</b>
Deposits on the spray cylinder.	Nozzle is not clean.	▶ Clean the nozzle. See Chapter 9.10 "Cleaning the nozzle", page 67
	Nozzle is defective (bent nozzle needle).	▶ Replace nozzle or defective part.
	Product will not dry.	▶ Reduce the temperature difference between entry and exit
		▶ Increase rate of gas spray flow (> 600 l/h)
		▶ Reduce peristaltic pump performance.
	Entry temperature is above the melting point of the product.	▶ Reduce entry temperature.
Product related deposits.	No action possible.	
Wide spray angle deposits droplet on the spray cylinder wall.	▶ Narrow the spray angle by adjusting the spray cap position.	
Glass elements become wet.	Peristaltic pump lever has become loose.	▶ Tighten lever.
Deposits in the cyclone.	Product related deposits.	No measure possible.
	Static charge build-up.	▶ Check gas supply pressure.
	Product too moist.	▶ Check tube condition.
	Temperature too high.	▶ Insert earthing cable.
▶ Increase exit temperature to dry the product.		
▶ Reduce aspirator performance to reduce residence time of product.		

### 10.1.2 Troubleshooting heater

Problem	Possible cause	Action
System does not heat up.	The heater is not connected properly.	▶ Check the heater plug.
	Nominal entry temperature is below room temperature.	▶ Pre-select a new inlet temperature.
	Fuse has blown	▶ Change the fuse. See Chapter 10.3 "Changing the fuse", page 72 ▶ Contact BUCHI Customer Service.
	Heater defective	▶ Replace the heater.
	Faulty tubing system (Faulty flow direction or no flow in the heating system)	▶ Check tubing system. ▶ Contact BUCHI Customer Service.
Exit temperature does not rise.	Sensor not inserted.	▶ Place probe in coupling element.
	Fault in tubing system.	▶ Check tubing system.
Entry temperature falls.	Heating is switched off.	▶ Switch on heating.
	Fuse has blown.	▶ Change the fuse. See Chapter 10.3 "Changing the fuse", page 72
Exit temperature falls.	Spraying too powerful	▶ Reduce production rate of peristaltic pump.
Exit temperature rises	Nozzle blocked	Clean the nozzle by actuating the cleaning button or by switching on cleaning nozzle Increase number of pulses for the nozzle cleaning activity
	Hose not dipped into stock solution Change of concentration in stock solution	▶ Dip hose into product. ▶ Agitate product (magnetic agitator) to obtain uniform concentration.
	No feed of product	▶ Switch on peristaltic pump

### 10.1.3 Troubleshooting aspirator

Problem	Possible cause	Action
Aspirator is noisy.	The aspirator is dirty.	▶ Clean the aspirator. See Chapter 9.3 "Cleaning the aspirator", page 64
	The operating mode is set to blow	▶ If no discharge filter is fitted, this should be done to avoid further contamination of the aspirator. ▶ Reset to suction mode if possible.
Insufficient aspirator performance.	Discharge filter blocked.	▶ Dismantle filter and clean it.

### 10.2 Nozzle does not atomize

- ▶ Check if all electrical connections are properly installed.
- ▶ Check the nozzle power setting on the controller.
  - ⇒ Make sure that a sufficient setting is used.
- ▶ Check the peristaltic pump is working properly.
- ▶ Check all connections of the liquid feeding line.
  - ⇒ Insufficient liquid supply can cause a high temperature to build up on the nozzle.

### 10.3 Changing the fuse



#### **WARNING**

#### **Risk of electric shock with connected power supply cable.**

Serious injuries or death can result.

- ▶ Switch off the device.
  - ▶ Disconnect the power supply cable from the device.
- 
- ▶ Set the On/Off master switch to Off.
  - ▶ Disconnect the power supply cable from the device.
  - ▶ Unscrew the fuse carrier (2).
    - ⇒ Make sure the O-ring on the fuse carrier is not damaged.
  - ▶ Replace the defective fuse (1).
  - ▶ Screw in the fuse carrier.
  - ▶ Connect the power supply cable.



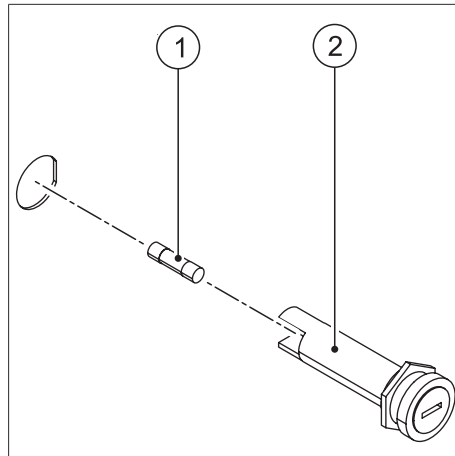

- ▶ If the fuse brakes repeatedly contact the Contact BUCHI Customer Service.

## 10.4 Sending instrument data to BUCHI customer service

### Navigation path

---



Precondition:

- A data storage device is connected to the instrument.

- ▶ Navigate to the *Home* menu according the navigation path.
- ▶ Tap the *[Support]* button.
- ▶ Save the data on the storage device.
- ▶ Send the data to BUCHI customer service.

## 10.5 No liquid delivery

- ▶ Check the condition of the tube used in the peristaltic pump.
  - ⇒ Replace a worn out tube.
- ▶ Adjust the peristaltic pump bed. See Chapter 7.8 "Adjusting the peristaltic pump bed", page 46

## 11 Taking out of service and disposal

### 11.1 Taking out of service

- ▶ Remove all solvents and coolants.
- ▶ Clean the instrument.
- ▶ Switch off the instrument and disconnect it from the mains power supply.
- ▶ Remove all tubing and communication cables from the device.

### 11.2 Disposal

The operator is responsible for proper disposal of the instrument.

- ▶ When disposing of equipment observe the local regulations and statutory requirements regarding waste disposal.
- ▶ When disposing, observe the disposal regulations of the materials used. Materials used see Chapter 3.5 "Technical data", page 20

### 11.3 Returning the instrument

Before returning the instrument, contact the BÜCHI Labortechnik AG Service Department.

<https://www.buchi.com/contact>

## 12 Appendix

### 12.1 Material information

#### 12.1.1 Feeding tube







Solvent	Silicone tube	Tygon MH 2375	Tygon F 4040 A
Methanol	+	+	+
Ethanol	+	+	+
Acetone	-	+	-
Toluene	-	-	-
Isopropanol	+	+	+
Chloroform	-	-	-
Dichloro methane	-	-	-
THF	-	-	-
Ethylacetate	-	+	-
Hexane	-	-	+
Acetonitrile (ACN)	-		

#### 12.1.2 Drying gas hoses

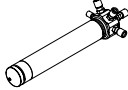
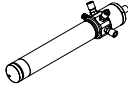
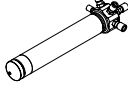
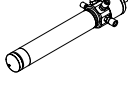
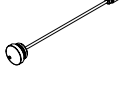
Medium	Concentration	Resistance	
	%	+20°C	+60°C
Chloroform	100	/	-
Dichloromethane	100	/	-
Methanol	100	+	+
Ethanol	96	+	+
Acetone	100	+	
Toluene	100		/
Acetonitrile	100	+	+
Tetrahydrofuran	100	/	-
Ethyl acetate	100	+	+
Hexane	100		/
Hydrochloric acid	100	+	+
Sulfur acid	50	+	+
Acetic acid	70	+	+
Formic acid	100	+	/
Sodium hydroxide	100	+	+
Ammonia	100	+	+
Water		+	+

## 12.2 Spare parts and accessories

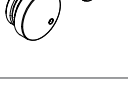
### 12.2.1 Nozzle

	Order no.	Image
<p>Three fluid nozzle, complete</p> <p>Nozzle for two independent sample feeds at the same time. Allows to spray dry immiscible samples for microencapsulation applications.</p>	046555	
Two fluid nozzle corrosives, complete	11056320	
Three-fluid nozzle corrosives, complete	11056971	
Two-fluid nozzle 0.7 mm, complete	044698	
Three-fluid nozzle conversion kit	046556	
Nozzle cleaning 0.7 mm, complete	044643	
Cleaning brush for nozzle	044782	
O-ring for nozzle cleaner, FKM (black), 2x	044469	
<p>Nozzle exchange set 1.4 mm, complete</p> <p>Wider diameter for the two fluid nozzle to work with viscous sample materials.</p>	046380	
Nozzle set 1.4 mm titanium, complete	11056415	
<p>Nozzle exchange set 2.0 mm, complete</p> <p>Wider diameter for the two fluid nozzle to work with viscous sample materials.</p>	046381	

	Order no.	Image
Nozzle set 2.0 mm titanium, complete	11056416	
Nozzle cleaning acid proof	11059876	
<b>Nozzle needle</b>		
	Order no.	Image
Needle 0.5 mm	11056864	
Needle 0.7 mm titanium	11056315	
Needle 1.4 mm	046372	
Needle 1.4 mm titanium	11056417	
Needle 2.0 mm	046373	
Needle 2.0 mm titanium	11056422	
Nozzle inside 0.7 mm	046554	
Nozzle inside titanium	11056969	
Needle for nozzle cleaning	044618	

**Nozzle tip**



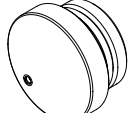
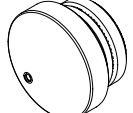

	<b>Order no.</b>	<b>Image</b>
Nozzle tip 0.5 mm	11056865	
Nozzle tip 0.7 mm	044634	
Nozzle tip 0.7 mm titanium	11056317	
Nozzle tip 1.4 mm	046376	
Nozzle tip 1.4 mm titanium	11056419	
Nozzle tip 2.0 mm	046377	
Nozzle tip 2.0 mm titanium	11056424	

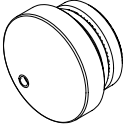
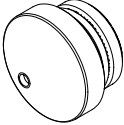
**Nozzle cap**

	<b>Order no.</b>	<b>Image</b>
Nozzle cap 1.4 mm	044649	
Nozzle cap 1.5 mm	044647	
Nozzle cap 1.5 mm titanium	11057509	

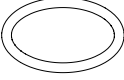
	<b>Order no.</b>	<b>Image</b>
Nozzle cap 2.2 mm	046374	
Nozzle cap 2.2 mm titanium	11057510	
Nozzle cap 2.8 mm	046375	
Nozzle cap 2.8 mm titanium	11057511	

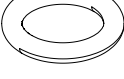
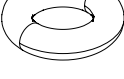

### O-rings nozzle

	<b>Order no.</b>	<b>Image</b>
Set of O-rings for nozzle	044759	
O-ring for nozzle, FKM (green), 2×	044645	
O-ring nozzle cap silicone (red), 2× 16.0 × 2.0 mm	002103	
O-ring for needle and nozzle tip, FKM (green), 4× 6.0×1.5 mm	004222	
O-ring for nozzle cleaner, FKM (black), 2× 3.0×1.5 mm	038348	
O-ring FFKM for screw coupling	046363	
O-ring for nozzle tip, FFKM (green), 2×	046361	

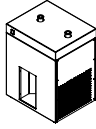
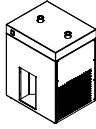
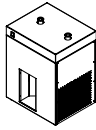
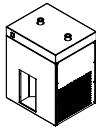
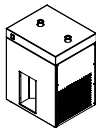
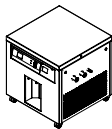
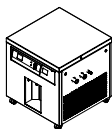
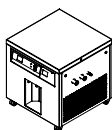
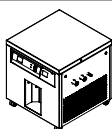
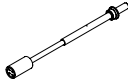
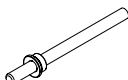
## 12.2.2 Accessories

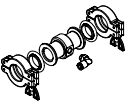
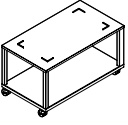
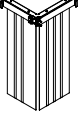
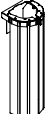
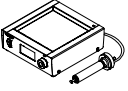
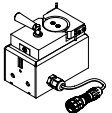
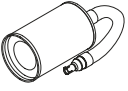

	Order no.	Image
Inert Loop B-295 Upgrade box	11074892	
Dehumidifier S-396 200 V	11073817	
Dehumidifier S-396 220 V	11074006	
Dehumidifier S-396 210 V	11073816	
Dehumidifier S-396 230 V	11073814	
Dehumidifier S-396 240 V	11073815	
Inert Loop S-395 200V 50Hz	11074620	
Inert Loop S-395 230V 50 HZ	11074621	
Inert Loop S-395 200V 60 HZ	11074622	
Inert Loop S-395 230V 60 HZ	11074623	
Cable product cover	11071611	
Ground pin Ø4 casing coated	11071709	

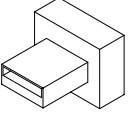

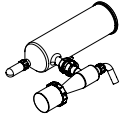
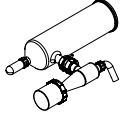
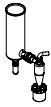

	Order no.	Image
Inert gas adapter S-300, complete	11074499	
Trolley S-300	11074575	
Protective curtain right, complete	11071754	
Protective curtain left, complete	11071651	
Ultrasonic package	11069892	
Peristaltic pump external Second peristaltic pump for three fluid nozzle, nozzle cooling or shorter distance between pump and nozzle.	11070786	
Inlet filter, complete Protects the sample from particles of the environmental drying air. Only for open mode.	011235	
Spray cylinder chrome steel kp	11064367	
Adapter USB-Wi-Fi/Bluetooth	11072500	
Oil-free compressor, 230 V/50 Hz	027907	
Compressed air maintenance unit	004366	
Oil-free compressor, 230 V/60 Hz	11055737	

### 12.2.3 Glassware

#### Glass assembly



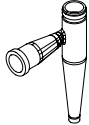
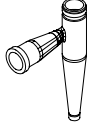
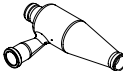

	Order no.	Image
Glass assembly S-300, complete	11071071	
Glass assembly S-300 brown, complete	11073658	
Glass assembly corrosive S-300, complete	11071420	
Glass assembly S-300 HP cyclone, complete	11074494	
Glass assembly S-300 HP cyclone brown, complete	11074495	

#### Cyclone



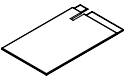

	Order no.	Image
Standard cyclone	004189	
Cyclone brown	11073659	
High-performance cyclone	046368	
High-performance cyclone, brownglass	11056879	
Cyclone with SVL 42	11071060	
High performance cyclone, complete	11074500	

	Order no.	Image
High performance cyclone brown glass, complete	11074496	

### Spray cylinder

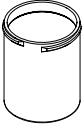

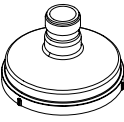



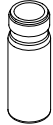

	Order no.	Image
Spray cylinder	044673	
Spray cylinder brown glass	044726	
Spray cylinder, vertical outlet	044697	
Spray cylinder, vertical outlet. brown glass	044728	
Cylinder insulation	040058	

### Collection vessel

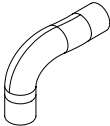
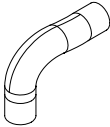
	Order no.	Image
Large collection vessel for standard cyclone 1.1 L	11056990	
Large product collection vessel for HP cyclone, complete	11056899	
Cover for large collection vessel HP cyclone	11056901	
Product collection vessel, brown glass	044727	
Product collection vessel	044678	

	<b>Order no.</b>	<b>Image</b>
Small product collection vessel for HP cyclone	046367	



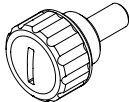

### Other glassware related spare parts

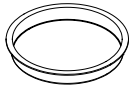

	<b>Order no.</b>	<b>Image</b>
Angle tube	11070485	
Angle tube brown	11073660	
Angle tube for HP cyclone	11073621	
Angle tube for HP cyclone brown	11074322	
Cap nut for cyclone	11070711	
Cover product vessel for cyclone	11072625	
Cover product vessel	11071425	
Coupling flange	11073537	
Coupling flange corrosives	11071421	
Knurled handle with recess	11071059	

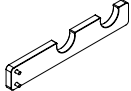
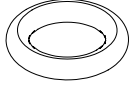
	<b>Order no.</b>	<b>Image</b>
Gasket SVL 42x35	11071061	
O-Ring 104 x 6.99 FKM 70	11071062	
Screw cap SVL 42	003551	
Separation flask	004188	
Push in connect NPQH-D-G1/8 Ø6	11071105	
Separation flask	004343	
Gasket FPM to waste vessel	040471	
Silicone seal SVL 42	040674	
Holder to spray cylinder	044710	
O-ring to spray cylinder	044711	
Screw to holder	044712	
Cover to product collection vessel	046318	

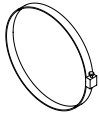
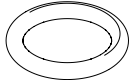
	Order no.	Image
Plastic closure for product collection vessel	046358	

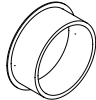
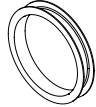
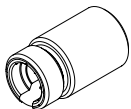

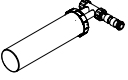
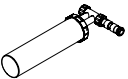
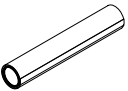
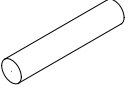
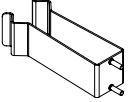
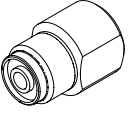



#### 12.2.4 Spare parts

	Order no.	Image
Set O-ring Plastiperfl. S-300	11074501	
	11071708	
O-ring Ø 5.00x1.50 Plastip.	11074587	
Ventilation hose aspirator, complete	11071064	
Hose clamp	11071067	
O-Ring Ø 27.94x5.33 FKM 75	11071073	
Quick release clamp	11071080	
Clamping lever M4	11071171	
Cover cap Ø 25.4	11071194	
Gasket SVL 42x35 PTFE	11071325	
Fixing nut T-sensor	11073019	

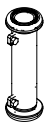
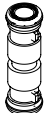
	Order no.	Image
Heater 2.3 kW 200 VAC conf.	11071353	
Outlet filter corrosives, complete	11071410	
Outlet filter corrosive, complete	11071411	
PTFE membrane filter	046316	
Polyester filter bags (6 units)	035004	
Filter holder grounded	11073770	
Adapter T-Sensor Outlet	11073020	
Pt1000 Temp. sensor 380mm coat	11071407	
Pt1000 Temp. sensor 380mm	11072982	
Silicone tube for nozzle cooling, 4 m	004139	
Tygon tube MH2375 transparent (per m)	046314	
Tygon tube F 4040 A yellow (per m)	046315	

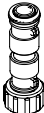
### 12.2.5 Hoses

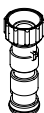
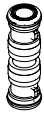
	Order no.	Image
Set tube PTFE	11072713	

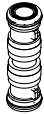
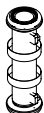
	<b>Order no.</b>	<b>Image</b>
Set tube PTFE corr.	11072714	
Tube Inert Loop PTFE conf.	11071602	
Hose Inert Loop TPR conf.	11071076	
Set hose TPR corr.	11071432	
Hose filter conf.	11071057	
Set hose dry gas TPR	11071431	
Set tubes for chiller	11073021	
Hose filter conf. corr.	11071413	
Hose TPR 0.7 m conf.	11071051	
Hose TPR 0.7 m conf.	11071052	
Hose TPR 1.0 m conf.	11071053	
Hose PTFE 0.7 m conf.	11071054	



	<b>Order no.</b>	<b>Image</b>
Hose PTFE 0.7 m conf.	11071055	
Hose PTFE 1.0 m conf.	11071056	
Hose TPR 0.7 m conf. coated	11071603	
Hose TPR 0.7 m conf. coated	11071604	
Hose TPR 1.0 m conf. coated	11071605	
Hose PTFE 0.7 m conf. coated	11071606	
Hose PTFE 0.7 m conf. coated	11071607	
Hose PTFE 1.0 m conf. coated	11071608	

### 12.2.6 Documents

	<b>Order no.</b>
Set IQ/OQ S-300 en	11074567
Repeating OQ S-300 en	11074568

---

We are represented by more than 100 distribution partners worldwide.  
Find your local representative at:

[www.buchi.com](http://www.buchi.com)

Quality in your hands

---